



Perspectives and evolution of reciprocating cogeneration systems

Pasquale Campanile



Pasquale Campanile

He is graduated in Electrical Engineering at Politecnico di Torino.

Currently, he is manager at the Centro Ricerche Fiat. For the energy sector applications he is responsible of the projects that involve the technical divisions of CRF and of the promotion of the research activities in terms of finding public funds and industrial partners.





Energy Management System Workshop
Torino, 24-25 May 2007

Perspectives and evolution of reciprocating cogeneration systems

Pasquale Campanile
CRF



Levelized Costs of Energy (*)

Source: NREL 2003

Technologies	Capacity [kW]	2005 [c\$/kWh]	2010 [c\$/kWh]
Reciprocating Engines	100	6,3	5,8
Microturbines	100	7,9	6,9
PEM Fuel Cell	200	13,3	10,1
MC Fuel Cell	250	17,3	11,5
SO Fuel Cell	100	13	9,6
Stirling Engines	55	NA	NA

(*) value for the price of the electric output that yields a total after tax internal rate of return of 15%.

Computed on a 20-year time horizon, including technology changes, O&M and projections for energy prices

Efficiency of the generation technologies depending on the installed capacity

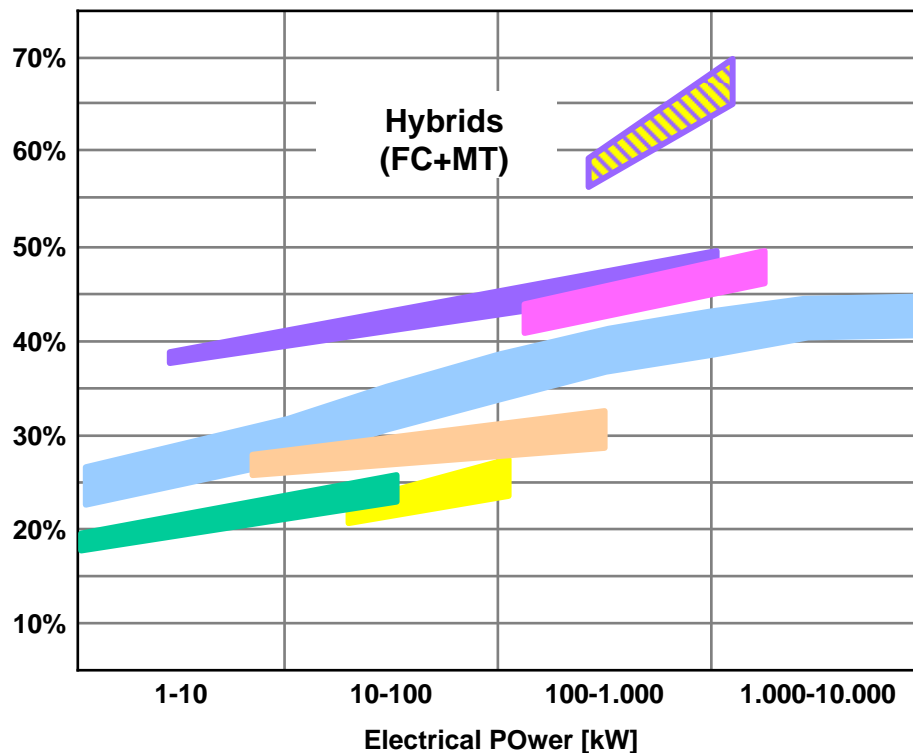
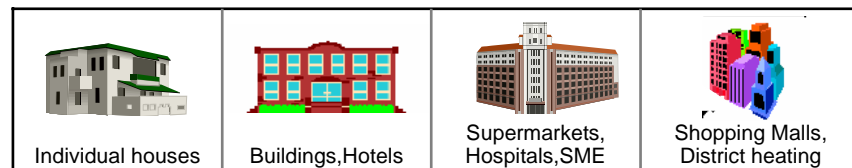

Capital cost

- Engine module accounts for more than one half of the total cost
- Installation costs can be partly reduced / incorporated into BOP equipment (e.g. electrical / thermal plant interfaces)

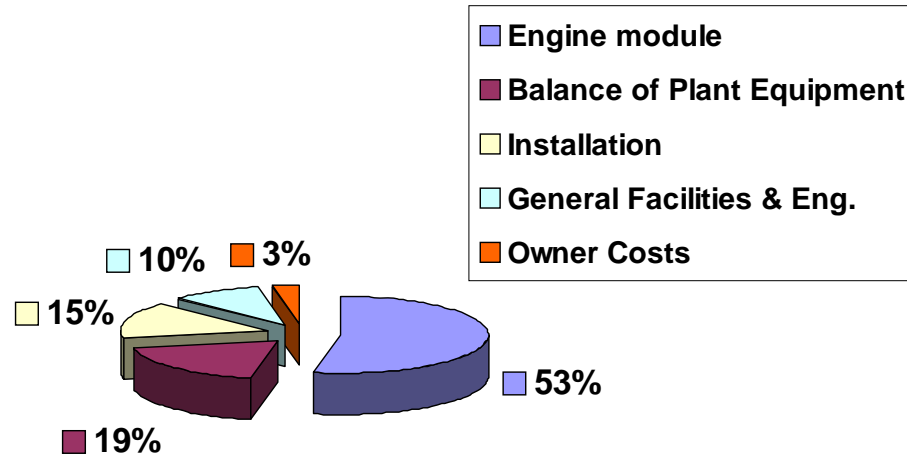

Total installed cost of a 500 kW ICE cogenerator

Source: WADE, 2005

O&M cost

- Maintenance strongly influences net energy cost
- Typical all-inclusive maintenance contracts rates range from 0,7 to 2 c€/kWh depending on power size, engine speed and customer location

Cogeneration cost items	Civil user [c€/kWh]	Industrial user [c€/kWh]
Primary energy (incl. Tax)	10,02	10,02
Maintenance	1,5	1,5
Avoided (incl. Tax)	-9,32	-6,21
Net energy cost	2,2	5,28

Indicative values for the Italian market

Reference efficiencies for a 100 kW system

There is a **growing demand** for micro-cogeneration applications mainly motivated by the following reasons:

- **Efficiency:** push on end use efficiency (fossil fuel savings, Kyoto protocol)
- **Cost:** competitive alternatives to conventional energy service
- **Safety:** grid decongestion and less vulnerable generation capacity

Such demand envisages **new product solutions and service** aiming at the following targets:

- **New** business model
- **Near zero emissions:** for convenient applications in urban areas
- **Easier interfacing:** for more effective integration into grids and buildings
- **Superior power quality:** for higher end applications
- **Fuel diversification:** for being able to use also renewable fuels
- **Automation and telematic mgmt:** for more effective energy services

Business model

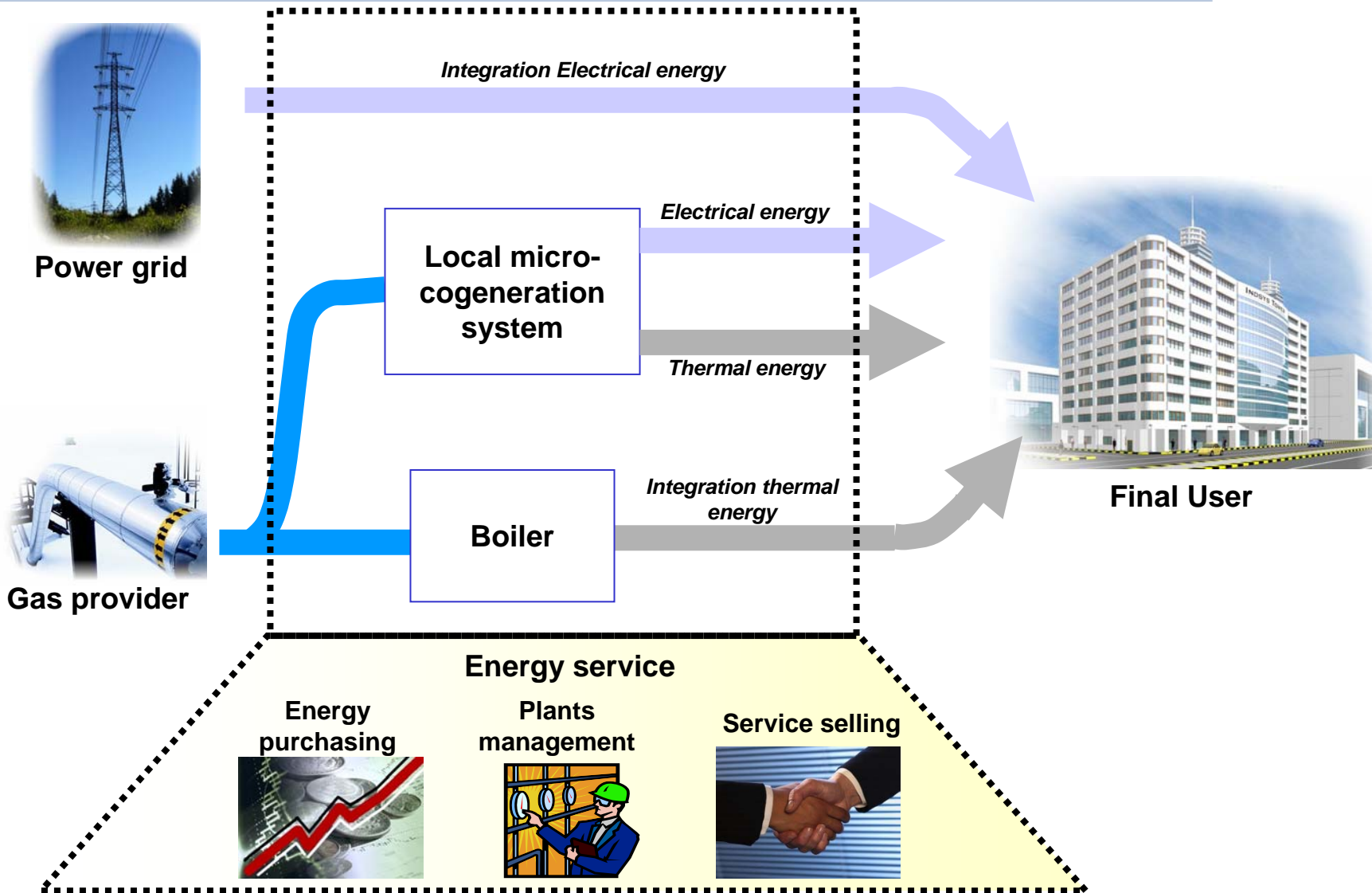

CRF has developed an innovative cogeneration system.

The main features are the following:

- **Automotive derived natural gas engine**
(stoichiometric, turbocharged, 3W catalyst)
- **Asynchronous generator**
- **Static power converter**
- **Open loop** heat recovery.



The **main innovation** is in the **control system**:

- Power regulation at variable speed
- Full automation and telematic management.

Nominal electrical power	120 kW
Nominal thermal power	187 kW
Dimensions	3,5m x 1,2m x 1,9m
Engine type	FPT Tector
Displacement	5883
Cylinders arrangement	6L
Fuel	Natural Gas
Compression ratio	11:1

CRF cogeneration system vs conventional (boiler + centralized electric production)

Local NOx emissions (mean value)

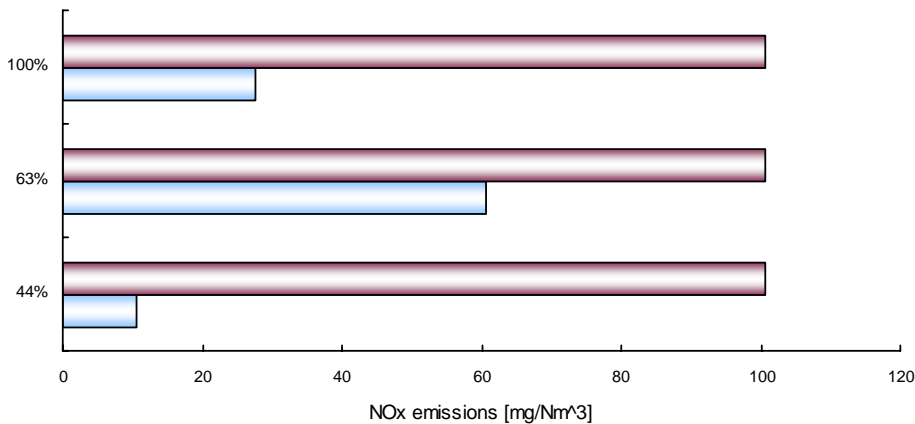

Global CO2 emissions

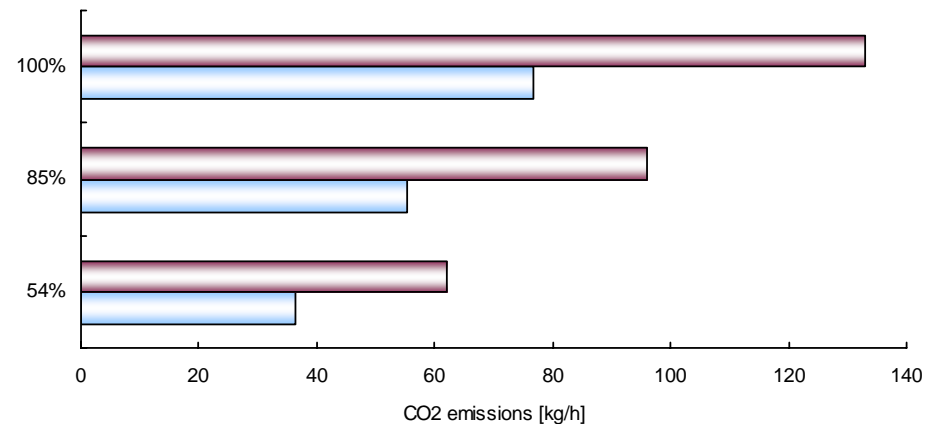

CRF cogeneration system

NO _x emission test	
samples	120
confidence interval	68.3%.
CO ₂ emission	Stoichiometric calculation

Reference values (ref. Piemonte air quality regulation)

Italian thermo-electric production

Electrical Efficiency	38%
CO ₂ emissions	618 g/KWh _e (source APAT 2004)

Boiler

Thermal efficiency	90%
NO _x emissions (@5%O ₂)	100 mg/Nm ³

Due to the application of advanced high efficiency engine, the CRF system shows higher efficiency at rated power (32,5% vs 28%).

Due to its unique variable RPM power control, CRF system efficiency remains almost constant at partial loads (30% vs nearly 17% @ 30% of rated power).

Application consequence

The higher the energy efficiency the lower the variable cost of the energy produced.

Nearly constant efficiency at partial loads provides the CRF system with a unique capability of following variable demand load profiles in a profitable way.

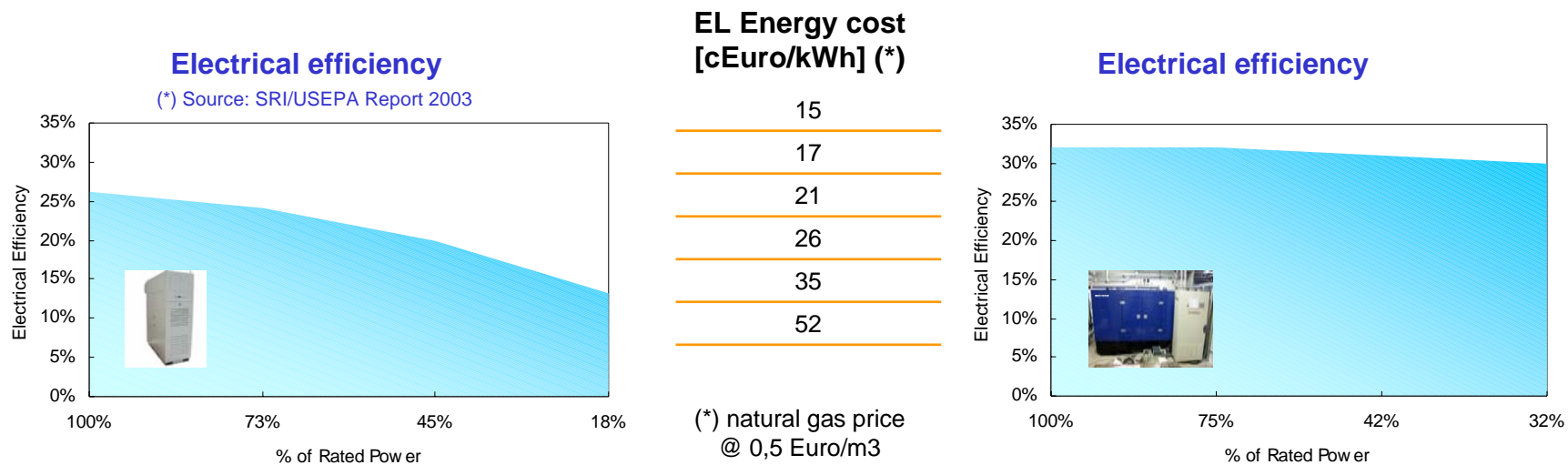

Due to the application of ecological new generation engines, the CRF cogenerator produces emissions comparable with microturbines at rated power (80÷305 vs 68 mg/kWhe).

Due to its unique variable RPM power control, CRF cogenerator emissions are lower at partial loads.

Application consequence

Both systems locally emit less pollutants than a high quality natural gas boiler to produce the same amount of heat (= electrical power is “emission neutral”).

NOx emissions

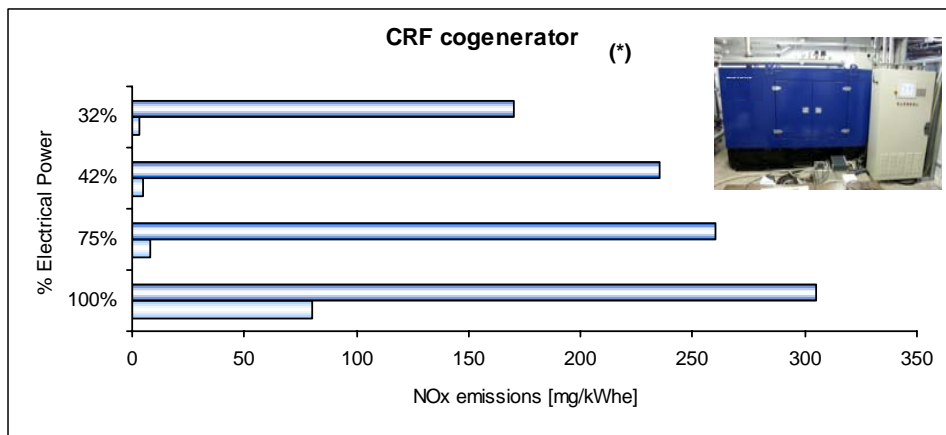

(*) Values to be consolidated. Minimum and maximum test results are represented

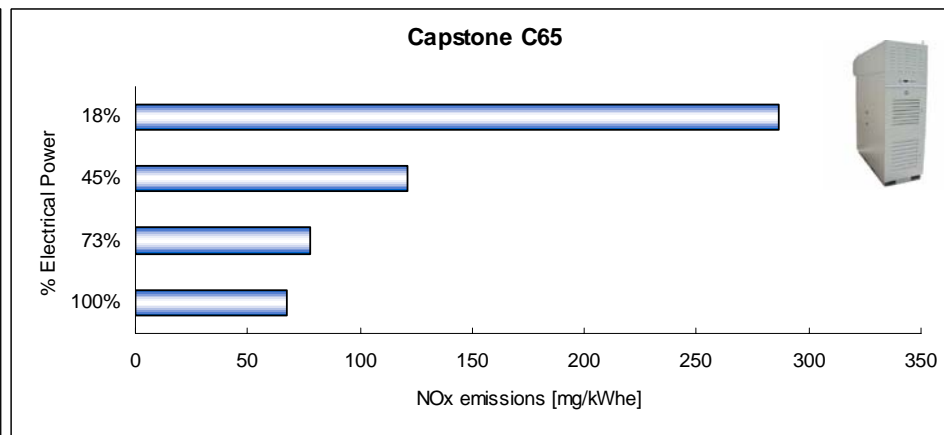





(*) Source: SRI/USEPA Environmental Technology Verification Report “CHP at a Commercial Supermarket - Capstone 60 kW Microturbine System” 2003

From smart vehicles to smart buildings ...

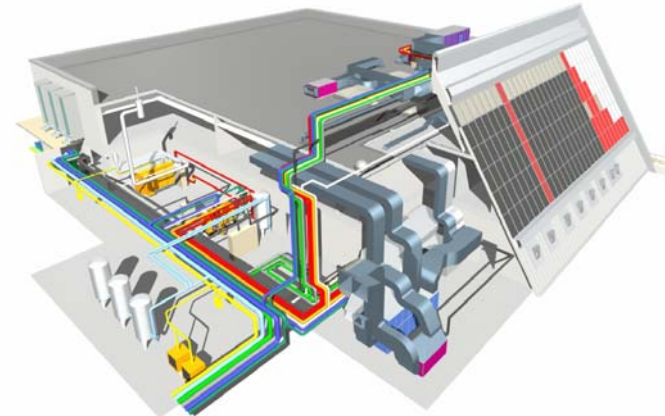
- Plants & Architectural integration
- Automation & control
- Telematic Management

CRF Eco-Canteen

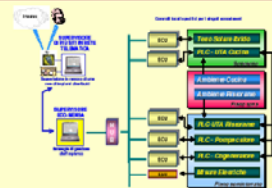
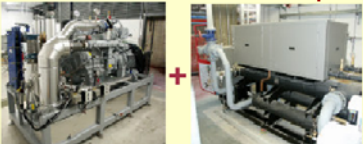

<p>Hybrid Solar Roof (Thermo-Photovoltaic)</p>  <ul style="list-style-type: none"> • Sup. attiva: 160 m² a 53 °S • Celle policristalline • Potenza elettrica: 20 kWp • Potenza termica: 100 kWp (9000 m³ h d'aria temp. media di 40° C) • Struttura modulare ed espandibile. <p>Il tetto solare ibrido produce in modo combinato elettricità ed aria calda</p>	<p>Telematic Management</p> 
<p>NG Trigenerator</p> <p>Cogenerator + Heat Pump</p>  <p>Produce in modo combinato energia elettrica e acqua calda</p> <p>Pot. elettrica: 50 kW max Pot. termica: 102 kW max (9 m³ h d'acqua a 90°C)</p> <p>Reversibile (produce acqua calda d'inverno e acqua fredda d'estate)</p> <p>Pot. termica: 296 kW max Pot. frigorifera: 215 kW max</p>	<p>Advanced Air-Conditioning MGM</p>  <ul style="list-style-type: none"> • Sistema desiccant a ruota entalpica • Controllo integrato temperatura-umidità <p>Unità di trattamento aria a ruota entalpica</p>

Impact calculated wrt the precedent Natural gas system

- 43% CO2 (115t)
- 33% Primary Energy (26,4 tep)
- 25% Operation Costs

Phase 1	March 2003	Hybrid Solar Roof
Phase 2	December 2003	<ul style="list-style-type: none"> • Cogenerator +Heat Pump • Desiccant cooling • Telematic system
Phase 3	March 2006	Continuous near zero emissions



**First Prize
EUROSOLAR 2003**



Co-funded by:



- "10000 Photovoltaic rooftop" program
- Demonstration projects 2004

From vehicles fleets to “Static Fleets” ...

Distributed Energy Services

- Energy management
- Supply Monitoring
- Plant Monitoring

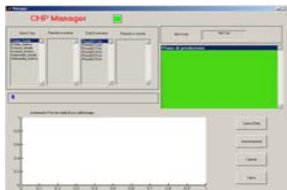
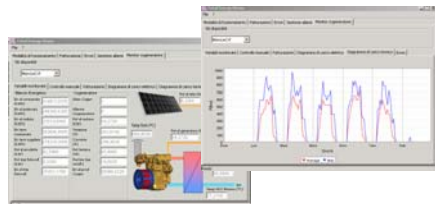

Developed for: EDISON

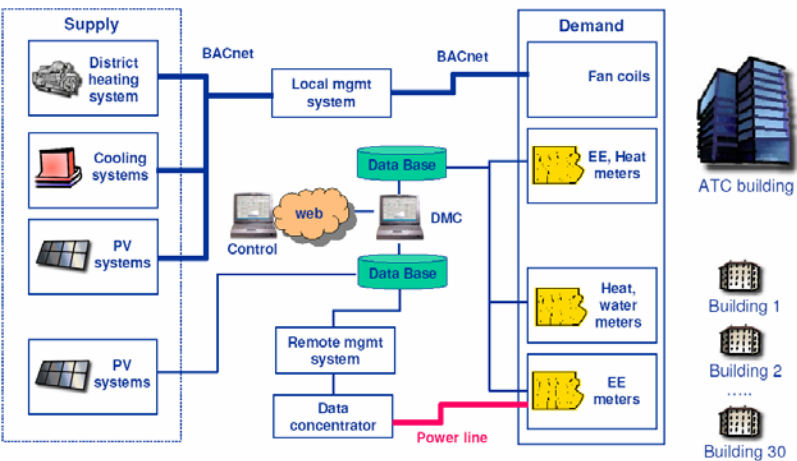
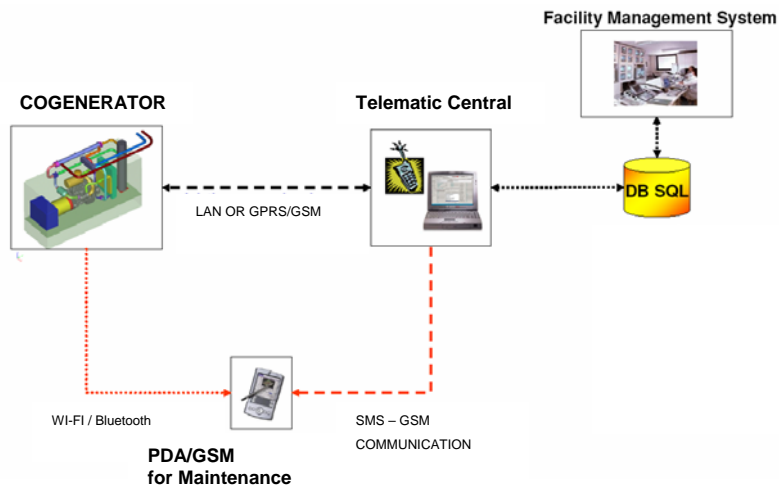

District tele-management (POLYCITY Project)

Arquata District, 2500 people, 31 buildings

1. **Monitoring:** energetic flows and plants states;
2. Plants **Scheduling & Management;**
3. **Billing Services & business evaluation**
4. **Tools for Customer Relationship Management.**

Developed with:

Trigeneration by integration with a liquid desiccant system

DEMONSTRATION SITE

The building, in the city of Torino – Italy, comprise seven University lecture halls within the Polytechnic of Turin premises.

The building is currently heated in winter through an all-air system integrated with hot water heaters (heat, both for AHU and heaters, is provided by a connection to district heating). No cooling is present in summer.

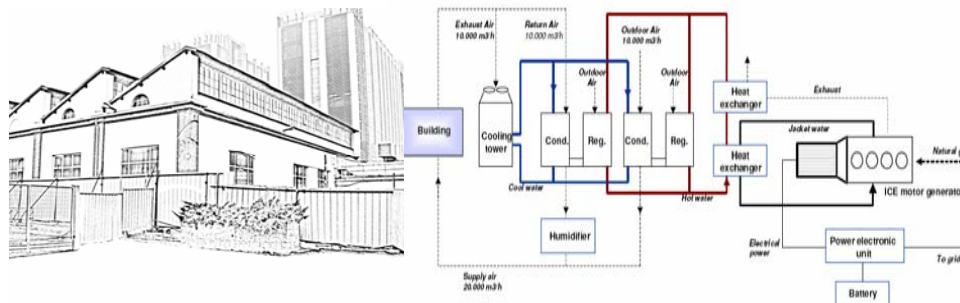

EXPECTED RESULTS

Electric	120 kW
Heating	187 kW
Cooling*	212 kW
Electrical efficiency (CHP)	33%
Total Efficiency (CHP)	85%
COP expected (Cooling)	1.1

Primary Energy Savings :

During Winter:	31 % (heat)
During Summer:	39 % (cool)

CO₂ Emission Savings

During Winter:	162 kg/h (heat)
During Summer:	61 kg/h (cool)

* external air @ 28.8°C 68% R.H.

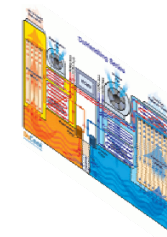
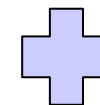
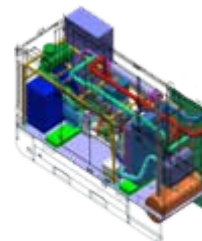

High efficiency cogeneration by integration with a small Rankine bottoming cycle

The system will have electrical efficiency about 40% and emissions of 539 gCO₂/kWh_e of electrical power produced, comparable with state of art centralised power generation.

In fact the average *Italian* energy mix (i.e. the overall efficiency of the centralised power production) is 38%, resulting in average 618 gCO₂/kWh (fuel mix includes also “CO₂ intensive” fuels such as coal) at the power station. Such value does not account for transmission and distribution losses that on average determine additional 7% emissions

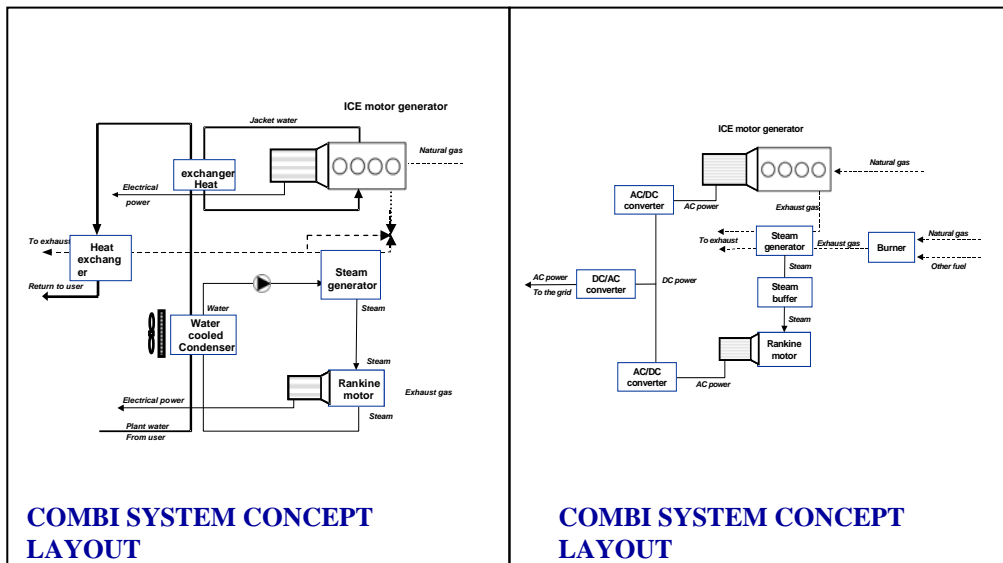

EXPECTED RESULTS

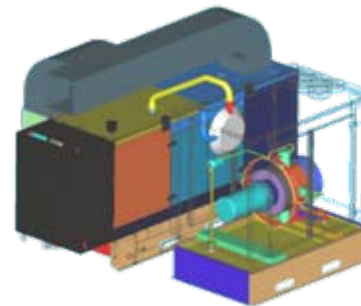

- Electric** ~142 kW
- Heating** ~ 165 kW
- Electrical efficiency** ~ 40%
- Total Efficiency** ~ 86%

- Primary Energy Savings :** ~ 39 %
- CO₂ Savings:** ~ 42%
- NO_x Savings:** ~ 73%

Reciprocating engines maintain a **substantial competitive advantage** over the other technologies for micro-cogeneration (< 1 MW).

In addition to traditional pro's (efficiency, cost, proven technology, maintainability) innovative concepts can achieve:

- **Outstanding emission performance**
- **More efficient and general applications**
- **New functions such as continuity, power quality and grid support**

Such innovations offer **new perspectives** to distributed generation:

- To integrate/substitute boilers at lower or equal local emissions
- To support the electric grids by means of distributed generation capacity
- To offer new and more competitive services to the final customers

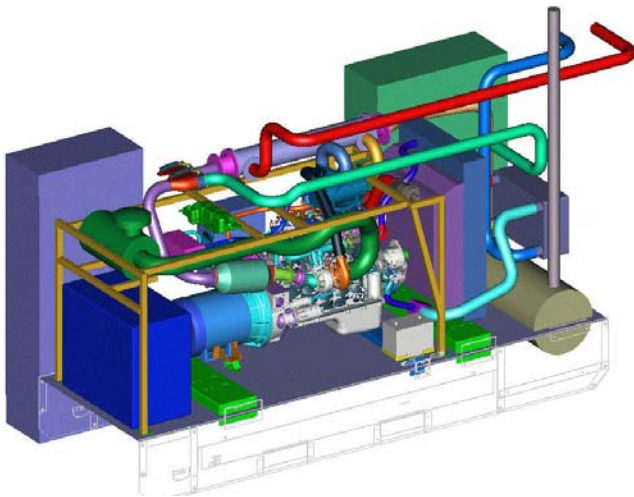

Thank you for your attention