

Multi-Objective Optimization of Biomass Conversion Technologies by Using Evolutionary Algorithm and Mixed Integer Linear Programming (MILP)

Samira Fazlollahi^{a,b}, François Maréchal^b, Magdalena Obrebska, Julia Markowska

^a Veolia Environnement Recherche et Innovation (VERI), 291 avenue Dreyfous
Ducas, 78520 Limay, France, samira.fazlollahi@epfl.ch

^b Ecole Polytechnique federale de lausanne, LENI-IGM-STI-EPFL Station 9- 1015
Lausanne, Switzerland, francois.marechal@epfl.ch

Abstract

The design and operation of energy systems are key issues for matching the energy supply and consumption. Moreover, in the present context of finding ways to decrease CO₂ emission, poly-generation technologies, together with the integration of renewable energy resources, have a high potential for CO₂ emission reduction.

An optimisation model and systematic procedure to select, size and operate a poly-generation plant are developed and presented in this paper. In the optimisation model the integration of biomass resources is mainly investigated.

Several options for integrating biomass in the energy system, namely back pressure steam turbine, biomass ranking cycle (BRC), biomass integrated gasification gas engine (BIGGE), biomass integrated gasification gas turbine, production of synthetic natural gas (SNG) and biomass integrated gasification combined cycle (BIGCC), are investigated in this paper. The goal is to minimize costs and CO₂ emission simultaneously with a multi-objective evolutionary algorithm (QMOO) and a Mixed Integer Linear Programming (MILP).

Finally the proposed model demonstrated by means of a case study. The results shown the simultaneous production of electricity and heat with biomass and natural gas are reliable upon the established assumptions. Besides, higher primary energy savings and CO₂ emission reduction are obtained through the gradual increase of renewable energy sources compare to the natural gas usage.

Keywords

Poly-generation systems, Mixed Integer Linear Programming, Evolutionary algorithm, Biomass conversion technologies, CO₂ mitigation

1. Introduction

With respect to global issues of sustainable energy development and reduction of CO₂ emission, biomass is getting increasing attention as a potential source of renewable energy [7]. Poly-generation technologies, together with the integration of biomass have a good potential for CO₂ emission reduction. With the development of technologies in the energy field, various biomass conversion technologies producing heat, power, and liquid fuels, such as pyrolysis,

gasification, combustion with coal, are understudied [5,4]. Biomass is a CO₂ neutral resource and distributed extensively. More over, if any CO₂ mitigation technology is adopted, negative CO₂ emission will be realized, which can reduce the emission in atmosphere [6].

In the present work, several options for integrating biomass in the poly-generation plant are studied, but before going forward, a systematic procedure is needed to select and size the equipments.

Diverse procedures exist to size cogeneration plants [3,8,9]. The most common methods are based on the thermal duration curves. Some limitations related to the economic evaluation and the CO₂ emission assessment may appear [9-11].

Mathematical optimization methods have proved their validity to formulate sizing and operating optimisation of energy systems. There is possibility of including constraints regarding profitability, energy saving and environmental impact in these methods. In thermal systems, the optimization process is usually applied in two levels: first the sizing and equipment selection, and second the operating optimisation [8,12]. The system operation is assumed as a succession of stationary states in some researches to avoid dynamic operation effects of equipments [13]. Multi objective optimisation of energy systems can be achieved through diverse optimization techniques, such as genetic and evolutionary algorithms, linear and non-linear programming [3]. In addition, selection and sizing of technologies in a poly-generation scheme, including a desalination unit, is investigated to find out the definite solution [14,16,17].

In the present work a multi-objective optimization model with evolutionary algorithm (QMOO), is developed (sec.2) to study the integrating of biomass in the energy system as well as sizing cogeneration plants. The developed model evaluates total costs and CO₂ emission simultaneously by decomposing the model into master and slave optimization. Finally developed model is demonstrated by means of a case study (sec.4.), and results are compared to conclude advantages and disadvantages of alternative solutions (sec.4.1).

2. Methodology overview

In energy systems, conversion technologies are used to transform the primary energy into useful services. Several technologies may be used simultaneously or in competition in order to satisfy the energy requirement at a minimum cost. In this work, multi-objective optimization techniques are performed to investigate sizing and operating effects of poly-generation plant on CO₂ emission. The basic concept of the developed model is the decomposition of the problem into several parts, as illustrated in Figure 1.

Following the conceptual process design methodology [1], first in the master optimization, the type and the maximum size of equipments (hot and cold utilities) are initialized by using evolutionary algorithm (QMOO) (sec.2.1).

In the second step, thermodynamic state variables of selected equipments are calculated by using thermodynamic models (ETM). The goal of these models is to figure out the heat transfer, power requirements and thermodynamic states (e.g temperature and pressure) of equipments. In this study, such nonlinear models are developed.

The results of previous steps are used in the energy integration step (EIO) (sec.2.2.). EIO is the Mixed Integer Linear (MILP) optimisation model. The size and the operating condition of selected equipments are optimized in this step. The objective function is minimizing the operating cost under the heat and power cascade constraints.

After identifying systems' configuration, the environomic¹ evaluation (EE) is performed for design objectives. These steps and their interactions are integrated in the multi-objective optimization framework (QMOO). Finally, set of solutions are presented by Pareto curve.

¹ Environomic is an expression combining environment, economics and thermodynamics

2nd European Conference on Polygeneration – 30th March -1st April 2011 – Tarragona, Spain
The communication between the software used for the different modelling and optimization steps has been realized by developing a computational platform programmed in Matlab language [2].

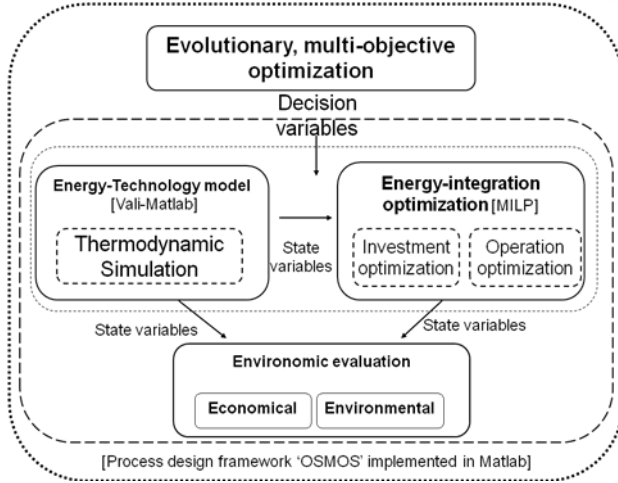

Figure 1: Overall decomposition optimization sequence

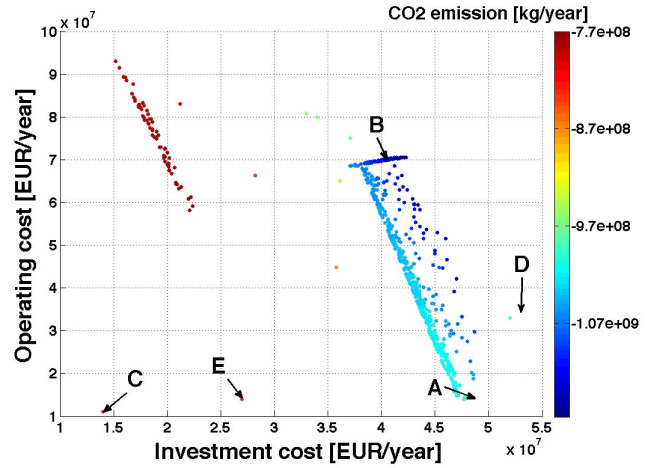

Figure 2: Multi objective optimisation results: QMOO

2.1 Evolutionary, Multi-objective optimisation (QMOO)

Multi-objective optimization techniques have been introduced in the conceptual design of energy conversion systems in order to provide an enlarged set of candidate solutions for a design problem that is characterized by several conflictive objectives such as efficiency, cost and environmental impact (see, for example [20]; [21]; [22] and [23] for CHP plants, [24] for internal gasification combined cycles). Due to their ability of handling non-linear and non-continuous objective functions, evolutionary algorithms have thereby proven as a robust method for solving such complex programming problems.

In this paper, QMOO based on the evolutionary algorithm is performed to investigate sizing and operating effects of poly-generation plant on CO₂ emission. The model is decomposed into the master optimisation, simulation models (ETM), the slave optimization (EIO) [25] and the environomic evaluation (EE). The nonlinear master problem is solved using an evolutionary algorithm (QMOO) [29], with three objectives being the minimization of annual investment and operating costs, and CO₂ emissions (Eq.1):

$$\min_{Q_s, \mathcal{N}_s} [OPEX, CAPEX, M_{CO_2}] \quad s.t. \{ETM, EIO, EE\} \quad (1)$$

Binary variables, for the choice of the equipments and their maximum available capacity, are decision variables in the master optimization. The slave optimization, $\min [EIO]$, is the MILP model described in sec.2.2. The minimization of the total cost including the CO₂ taxes is the objective function in the slave optimization. The size and the operating condition of selected equipments are main decision variables in the slave optimization. Finally the results of QMOO are presented by the Pareto optimal frontier.

2.2 Multi period energy integration (EIO)

Once the state of equipments and their associated heat requirements are determined in ETM step, the extensive part of the problem can be solved by MILP. The mass balances between the system's elements and the heat cascade are defined as constraints in MILP. The selection of the objective is thereby arbitrary as long as the aggregation of the terms is robust and consistent with respect to the multiple objectives of the master optimization problem. In this work is proposed to minimize the total operating and emission costs. For all subsystems s that provide j

output and consume i input streams through the system boundary, the target can be expressed as a function of their utilization level, f_s , to be optimized, i.e.:

$$\min_{\substack{R_{e_{l,t}}, R_{r,t}, y_{s,t}, f_{s,t}}} \sum_{s,t} f_{s,t} \left(\left[\sum_i Q_{s_i,t}^+ C_{i,t}^+ - \sum_j Q_{s_j,t}^- C_{j,t}^- + \sum_l (cel_{l,t}^+ * \dot{E}_{s,l,t}^+ - cel_{l,t}^- * \dot{E}_{s,l,t}^-) \right] * d_t + M_{CO_2,s} * tax_{CO_2} \right) + (cel_{N_{l,t}}^+ * \dot{E}_{grid,t}^+ - cel_{N_{l,t}}^- * \dot{E}_{grid,t}^-) * d_t \quad (2)$$

Subject to:

Existence of subsystem s :

$$f_{min,s} * y_{s,t} \leq f_{s,t} \leq f_{max,s} * y_{s,t} \quad \forall s = 1, \dots, N_s \text{ and } \forall t = 1, \dots, T \quad (3)$$

Heat balance of the temperature intervals r and its overall balance:

$$\sum_{s,i,j} f_{s,t} (Q_{s_j,r,t}^- - Q_{s_i,r,t}^+) + R_{r+1,t} - R_{r,t} = 0, \quad R_{1,t} = 0, \quad R_{N_r+1,t} = 0, \quad \forall r, t \quad (4)$$

The CO₂ emission of the net electricity import from the grid and the fuel consumption are considered, if the CO₂ emission of the electricity from the grid is higher than the emission from a poly-generation plant, then negative CO₂ emission will be realized:

$$M_{CO_2,s} = \sum_{t,j} (Q_{s_j,t}^- / \eta_{th,s} * d_t * m_{CO_2}) + \sum_t (\dot{E}_{grid,t}^+ - \dot{E}_{grid,t}^-) * d_t * m_{grid,CO_2}, \quad \forall s \quad (5)$$

Electricity demand of a consumer in a period t can be satisfied with the direct power from equipments or from the main power grid. Different quality levels are considered for electricity production and denoted by $l = 1, \dots, N_l$. The highest quality is $l = N_l$ and the lowest one is $l = 1$. As an assumption, the electricity export and import from the grid has the lowest quality. There is also a possibility of cascading the residual electricity from the higher quality ($\dot{R}e_{l,t}^-$) to the lower quality levels.

$$\sum_{s,l} f_{s,t} (\dot{E}_{s,l,t}^+ - \dot{E}_{s,l,t}^-) = \dot{E}_{grid,t}^+ - \dot{E}_{grid,t}^-, \quad \dot{E}_{grid,t}^+ \geq 0, \quad \dot{E}_{grid,t}^- \geq 0, \quad \forall t \quad (6)$$

$$\sum_{s,t} f_{s,t} (\dot{E}_{s,l,t}^- - \dot{E}_{s,l,t}^+) - \sum_t \dot{R}e_{l,t}^- + \sum_t \dot{R}e_{l+1,t}^- = 0, \quad \forall l \quad (7)$$

$$\dot{R}e_{N_{l+1},t}^- = 0, \quad \dot{R}e_{l,t}^- = \dot{E}_{grid,t}^- - \dot{E}_{grid,t}^+, \quad y \in \{0,1\}, \quad R_r \geq 0, \quad \dot{R}e_{l,t}^- \geq 0, \quad (8)$$

The utilization level of subsystem of type demand is fixed and equal to 1, $f_s = 1 \quad \forall s = demand$, but the utilization level of poly-generation units as utility subsystems, f_s , are variable and being optimized.

3. Alternative biomass conversion technologies

The five alternative equipment options (Figure 3), investigated in this paper, for integrating biomass in the energy system are the following:

Back pressure steam turbine (BPST): It is the most common technology used in CHP plants. The biomass-fired boiler produces high pressure steam, which is expanded in the backpressure turbine for electricity generation. The low-pressure steam extracted from the turbine is then used in the district heating network.

Biomass Rankin Cycle (BRC): Biomass is combusted in a boiler. The boiler is coupled with BRC by a closed thermal oil cycle. The organic working fluid is vaporized by the hot oil and expanded in a turbine for electricity generation.

Biomass integrated gasification gas engine (BIGGE): In this configuration, biomass is used in the gasification process carried out with oxygen and steam at high temperatures in circulating

2nd European Conference on Polygeneration – 30th March -1st April 2011 – Tarragona, Spain fluidized bed (CFB) gasifier. The produced gas, after tar cleaning and cooling down, is fired in a gas engine for heat and electricity production. There is also the possibility of integrating a steam turbine after the gas engine.

Biomass integrated gasification gas turbine (BIGGT): Here, the gas produced by gasification is burned in a gas turbine after tar cleaning and cooling down procedures. The heat from exhaust gases are extracted for the district heating.

Biomass integrated gasification combined cycle (BIGCC): It is the combination of gasification with gas turbine and steam cycle. First the biogas produced by gasification is cleaned from tars and particular matters. After that it is burned in the gas turbine. Exhaust gases are used in the heat recovery steam cycle. Steam is expanded in the turbine and remaining heat is used in the district heating system.

Production of synthetic natural gas (SNG): It is from biomass gasification process. Methane synthesis is used to increase calorific value of the produced gas, after tar cleaning and cooling down procedures. Finally the carbon dioxide is removed. The obtained synthetic natural gas can be sold and sent to the gas grid. The heat obtained during SNG production can be used in the district heating. In this study the model proposed by M.Gassner [27] is used to simulate SNG unit.

Following the second step of methodology, thermodynamic models are developed for these five alternative options by using commercial flowsheeting software, Belsim.

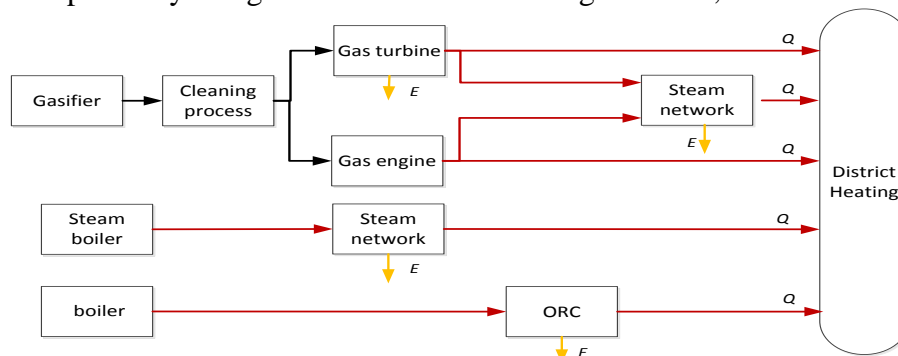

Figure 3: Alternative biomass conversion technologies

4. Illustrative example

An illustrative example of the model usage is presented in this section. The case comprises five alternative units, BPST, BRC, BIGGE, BIGCC and SNG, for power and heat services. It should indicate that all units are assumed to be able to operate at any time throughout the whole periods. The obtained synthetic natural gas can be sold and sent to the gas grid with the green SNG price. The heat obtained and electricity produced during SNG production process can be used in the district heating [27]. The reference size and capacity ranges of equipments are given in Table 1. Economical and technical information of each technology were taken from the literature [17-19].

Any combinations of these five options are allowed with two types of available resources; biomass and natural gas (see Table. 2). As an assumption, the biomass boiler with 80% efficiency has 2 times more maintenance cost compare to the natural gas boiler. Consumers' heat demands are given for 12 periods and one extreme condition, with corresponding duration, in Table 3. This demand profile is valid for a city with the population of 550,000 in Eastern Europe. Besides, power generation is considered as an opportunity for producers.

Regarding the optimization part, the integer variables are defined in the master optimization to select the type of equipments, while continues variables are used for setting the maximum available capacity of selected equipments. The CO₂ weighting factor for taxes, varied from 0 to 0.5 [€/kg] is also defined as a continuous variable in the master optimization. The fuel choice and the utilization level of selected equipments are left to the slave MILP optimization. If the

selected capacity in the master optimization is underestimated, a back up boiler is defined in the slave optimization to cover all heat demand.

4.1 Results and discussion

To make the optimization of the test case, 1500 iterations of the master optimizer have been carried out by parallel computing on a high-performance cluster (EPFL Pleiades cluster) and resulted in an initial population of 100 plant configurations shown on the Pareto curve in Figure 2.

This figure shows two main clusters. One, with higher operating cost and higher CO₂ emission features gas turbines, engines and SNG. The second cluster features gasifiers, gas turbine, engines, boilers and SNG with higher investment cost.

Table 1: Reference capacity of each equipment

Equipment	Reference capacity [MW _{th/el}]	Ranges [MW _{th/el}]
Boiler (NG)	42 _{th}	[0 4200]
Boiler (BM)	42 _{th}	[0 4200]
Engine (NG)	5 _{el}	[0 500]
Engine (BM)	5 _{el}	[0 500]
SNG	14 _{th}	[0 200]
Gasifier	14 _{th}	[0 2000]
Gas turbine (NG)	20 _{el}	[0 2000]
Gas turbine (BM)	3 _{el}	[0 300]
BRC	2 _{el}	[0 200]

el: electrical capacity, th: thermal capacity

Table 2: CO₂ Intensity and Price of available resources

Resources	CO ₂ : [Kg/kWh]	Price: [€/kWh]
Electricity	1.1	0.167
Natural gas	0.231	0.098
Biomass	0	0.08
Engine (BM)	0	0.1007

Five interesting configurations, among all solutions, are selected to study in details. Figure 4 shows the overall supplied heat and power, fuel consumption and heat demand of 5 selected configurations, during 6966 hours of a year.

Table 3: Twelve periods data set for the heating demand

	January	February	March	April	May	June	July
Duration [h]	744	672	744	720	604	424	285
T_{mean} [C]	1.87	4.93	7.78	11.4	14.05	15.76	16.7
Q_{mean} [MW]	350	310	300	200	90	70	60
	August	September	October	November	December	Extreme	
Duration [h]	160	492	658	719	744	1	
T_{mean} [C]	16.69	15.61	12.8	10.38	5.09	-8	
Q_{mean} [MW]	62	100	200	300	350	600	

These configurations are A with 0.005 CO₂ taxes [€/kg] and features SNG, steam networks, gasifier and gas turbine with biomass resources; B has the same configuration as A but without SNG production unit; C² features engines and steam networks. The only available resources is natural gas in this configuration. D features SNG, engines and gasifier but without steam networks, and finally E features boilers and steam networks. In this example, the obtained synthetic natural gas can be sold and sent to the gas grid with the green SNG price (Table 2), while the heat obtained and electricity produced during SNG production process can be used in the district heating [27]. Three objectives, investment and operating cost and CO₂ emission, of these configurations are summarized in Table 4.

Due to the high emission of electricity from the grid, compare to the poly-generation plant, the negative CO₂ emission is realized in these 5 selected solutions (Equation 5).

² The CO₂ emission of C and D are manipulated to represent clear colour bar in figure 2.

2nd European Conference on Polygeneration – 30th March -1st April 2011 – Tarragona, Spain
 Configuration C fuelled by only natural gas with 500 [MW] overall consumptions, while configuration B is used 700 [MW] biomass. Without considering CO₂ taxes, configuration B costs 60% more than C due to the lower incomes.

It shown, higher economic profitability is achieved with natural gas-based technologies compare to the biomass usage, while higher primary energy savings and CO₂ emission reduction are obtained through the gradual increase of biomass sources.

The configuration A with biomass resources emits [kgCO₂/kWh] 2 times less than configuration C with natural gas fuel resources. The effect of CO₂ emission of electricity from the grid is also included.

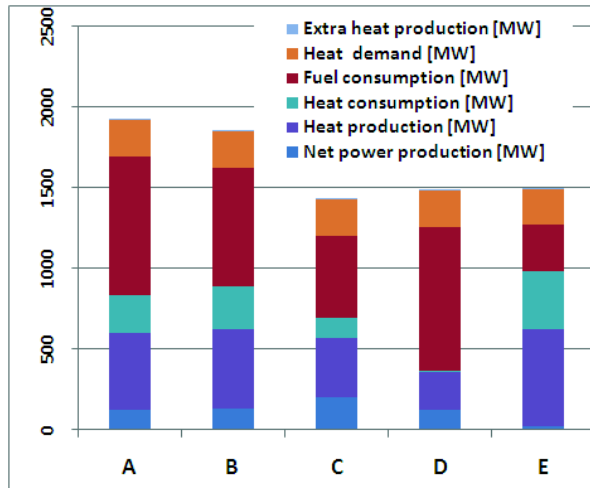

Figure 4: Comparison between 5 different configurations

Table 4: Objective functions and power production of 5 selected configuration

	Total cost without CO ₂ taxes: [million EUR/year]	Investment: [million EUR/year]	Operation [million EUR/year]	CO ₂ *10 ⁸ [kg/year]	Incomes [million EUR/year]
A	62	48	14	-9.8	150
B	108	39	69	-10	160
C	25	14	11	-7.4	230
D	85	52	33	-9.5	140
E	41	27	14	-1.9	29

Figures 5 and 6 show the carnot composite curve of configurations A and D. On the plots, the hot composite curve represents the heat provided by the poly-generation plant. The cold composite curve shows the consumers and production units' heat requirement. The cooling water is also considered for cooling down the system. There is an exergy losses in configuration D, while in configuration A, exergy losses is 80% decreased by integrating the steam networks with 120 bar pressure.

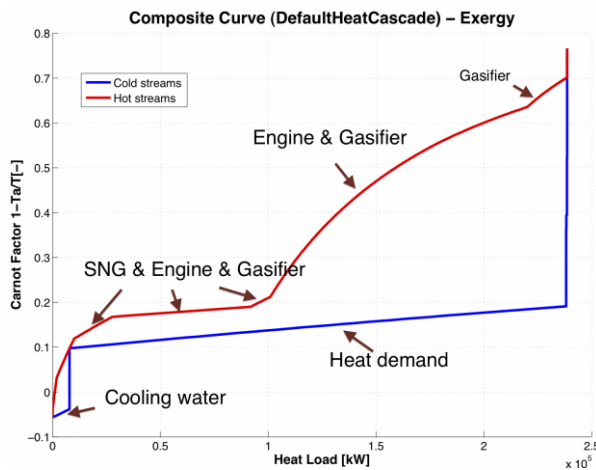

Figure 5: Carnot composite curve of configuration D

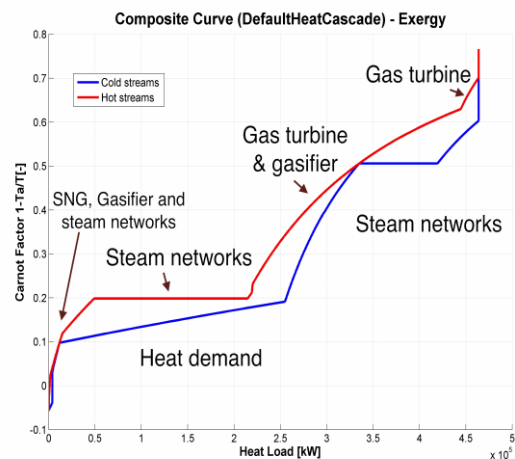

Figure 6: Carnot composite curve of configuration A

5. Conclusion

In this study, a Multi objective optimization model is developed to evaluate sizing and operating of a poly-generation plant based on the integration of biomass resources. The energy system has to meet the heat demands of a local area while considering both economic and

environmental objectives. The illustrative example demonstrates the ability of the developed method.

The consideration of several equipments with their thermodynamic properties together with simultaneous consideration of multi-periods and multi-objective aspects, are important features in the developed method.

From the results it appears that natural gas, compare to the biomass, is not attractive when CO₂ taxes is included, however it is sensitive to the CO₂ taxes and the resources' price. Without considering CO₂ taxes, higher economic profitability is achieved with natural gas-based technologies. Besides, higher primary energy savings and CO₂ emission reduction are obtained through the gradual increase of biomass sources.

The comparison between the carnot composite curves of configurations shows the advantages of using steam networks for decreasing exergy losses and CO₂ emission due to the high CO₂ emission of electricity from the grid. However, BRC is not any more attractive when steam network is integrated. Besides, the boiler is not competitive when the gas turbine with the gasifier can provide heat and electricity with lower CO₂ emission.

In conclusion, the developed model is able to study the effects of poly-generation technologies on environmental and economic targets by decomposition approach and parallel computing.

In the future study, the district networks and photovoltaics (PV), as well as storage system should be integrated in the optimization model.

Nomenclature

$f_{s,t}$	Utilisation rate of subsystem s in time t ,	$cel_{i,t}^+$	electricity import cost of quality l , in time t , [€/kWh]
$Q_{s_i,t}^+$	heat consumption of subsystem S_i in time t , [kW]	$cel_{i,t}^-$	electricity export benefit of quality l , in time t , [€/kWh]
$C_{i,t}^+$	heat consumption cost of subsystem S_i in time t , [€/kWh]	$\dot{E}_{s,l,t}^+$	electricity consumption with quality level l , in subsystem S in time t , [kW]
$Q_{s_j,t}^-$	heat production of subsystem S_j in time t , [kW]	$\dot{E}_{s,l,t}^-$	electricity supply with quality level l , in subsystem S in time t , [kW]
$C_{j,t}^-$	heat production benefit of subsystem S_j in time t , [€/kWh]	$\dot{E}_{grid,t}^+$	electricity import from the grid, in time t , [kW]
m_{CO_2}	CO ₂ emission of electricity production [kg CO ₂ /kWh]	$\dot{E}_{grid,t}^-$	electricity export from the grid, in time t , [kW]
$f_{min,s}$	minimum available capacity of S , [kW]	tax_{CO_2}	CO ₂ taxes, [€/kg CO ₂]
$f_{max,s}$	maximum available capacity of S , [kW]	EE	enviromonic evaluation
$\eta_{th,s}$	Thermal efficiency of subsystem s	d_t	Duration of period t , [hour]
m_{grid,CO_2}	CO ₂ emission of electricity from grid kg [CO ₂ /kWh]	$Re_{i,t}^-$	residual electricity from the quality level l , in time t
$M_{CO_2,s}$	CO ₂ emission produced by subsystem s	EIO	energy integration optimisation
$R_{r,t}^-$	residual heat from temperature level r , in time t	$y_{s,t}$	binary variables for existence of subsystem S in time t
ETM	Energy technology thermodynamic models	MOO	Multi objective optimisation

References

- [1] J. M. Douglas. A hierarchical decision procedure for process synthesis. Chemical Engineering and Processing: Process Intensification, pages 353–362, 1985.
- [2] R Bolliger. Methodologie de la synthese des systemes energetiques industriels. PhD thesis, Ecole Polytechnique Federale de Lausanne., 2010.

- 2nd European Conference on Polygeneration – 30th March -1st April 2011 – Tarragona, Spain
- [3] G. Chicco and P. Mancarella, Distributed multigeneration: a comprehensive view, *Renew Sustain Energy Rev* 13 (3) (2009), pp. 535–551
- [4] Devi L, Ptasinski KJ, Janssen FJJ. A review of the primary measure for tar elimination in biomass gasification processes. *Biomass Bioenergy* 2003; 24(2):125–40
- [5] E.D. Larson, T.G. Kreutz and S. Consonni, Combined biomass and black liquor gasifier/gas turbine cogeneration at pulp and paper mills, *J Eng Gas Turb Power* 121 (3) (1999), pp. 394–400.
- [6] Hongqiang Li, Hui Hong, Hongguang Jin, Ruixian Cai 2010, Analysis of a feasible polygeneration system for power and methanol production taking natural gas and biomass as materials. *Applied Energy* vol 87, no 9, pp. 2846-2853, China
- [7] Yan JY, Alvfors P, Eidensten L, Svedberg G. A future for biomass. *Mech Eng* 1997;119(10):94–6.
- [8] Frangopoulos CA. The European educational tools on cogeneration. Brussels, Belgium, COGEN Europe: The European Association for the promotion of Cogeneration; 2001.
- [9] E. Cardona and A. Piacentino, A methodology for sizing a trigeneration plant in mediterranean areas, *Applied thermal engineering* 23 (13) (2003), pp. 1665–1680.
- [10] A. Piacentino and F. Cardona, An original multi-objective criterion for the design of small-scale polygeneration systems based on realistic operating conditions, *Applied thermal engineering* 28 (17) (2008), pp. 2391–2404.
- [11] Y. Ruan, Q. Liu, W. Zhou, R. Firestone, W. Gao and T. Watanabe, Optimal option of distributed generation technologies for various commercial buildings, *Applied Energy* 86 (9) (2009), pp. 1641–1653.
- [12] C. Weber, F. Maréchal, D. Favrat and S. Kraines, Optimization of an SOFC-based decentralized polygeneration system for providing energy services in an office-building in Tokyo, *Applied thermal engineering* 26 (13) (2006), pp. 1409–1419.
- [13] P. Arcuri, G. Florio and P. Fragiaco, A mixed integer programming model for optimal design of trigeneration in a hospital complex, *Energy* 32 (8) (2007), pp. 1430–1447.
- [14] Rubio C, c. Feasibility analysis of a combined cooling–heating–power and desalted water plant in a non-residential building. In: *Proceedings of ECOS 2008*, vol. 3. Cracow, Poland; 2008.
- [15] C. Rubio, J. Uche and N. Dejo, Optimization of desalted water production in a polygeneration scheme for the tourist sector, *Desalination* 223 (1) (2008), pp. 464–475.
- [16] Rubio-Maya C. Combined production of electricity, heat, cold and fresh water, in a sustainable mode for the tourist sector, PhD thesis. Department of Mechanical Engineering, University of Zaragoza; 2009 (in Spanish).
- [17] Rubio C, Uche J, Gracia A, Design optimization of a polygeneration plant fuelled by natural gas and renewable energy sources, *Applied Energy* 88 (2) (2011), pp. 449-457.
- [18] Onovwiona HI, Ugursal VI. Residential cogeneration systems: review of the current technology. *Renew Sustain Energy Rev* 2006;10(5):389–431.
- [19] Wu DW, Wang RZ. Combined cooling, heating and power: a review. *Progress in Energy and Combustion Science* 32 (2006) 459–495
- [20] A. Toffolo and A. Lazzaretto. Evolutionary algorithms for multi-objective energetic and economic optimization in thermal system design. *Energy*, 27(6):549 – 567, 2002.

[21] A. Lazzaretto and A. Toffolo. Energy, economy and environment as objectives in multi-criterion optimization of thermal systems design. *Energy*, 29(8):1139 – 1157, 2004.

[22] Hongtao Li, Francois Marechal, Meinrad Burer, and Daniel Favrat. Multi-objective optimization of an advanced combined cycle power plant including co2 separation options. *Energy*, 31(15): 3117 – 3134, 2006.

[23] Hoseyn Sayyaadi . Multi-objective approach in thermo environomic optimization of a benchmark cogeneration system. *Applied Energy*, 86(6):867 – 879, 2009.

[24] David Brown, Martin Gassner, Tetsuo Fuchino, and Francois Marechal. Thermo economic analysis for the optimal conceptual design of biomass gasification energy conversion systems. *Applied Thermal Engineering*, 29(11-12):2137 – 2152, 2009.

[25] Weber celine. Multi-objective design and optimization of district energy systems including polygeneration energy conversion technologies. PhD thesis, Ecole Polytechnique Federale de Lausanne., 2008.

[26] G.B. Leyland. Multi-objective optimization applied to industrial energy problems. PhD thesis, Ecole Polytechnique Federale de Lausanne., 2002.

[27] Martin Gassner, Renato Baciocchi, Francois Marechal, and Marco Mazzotti. Integrated design of a gas separation system for the upgrade of crude sng with membranes. *Chemical Engineering and Processing: Process Intensification*, 48(9):1391 – 1404, 2009.

Acknowledgements

The authors would like to acknowledge the “Veolia Environnement Recherche et Innovation (VERI)” for the financial support.