

Turn waste heat into electricity by using an Organic Rankine Cycle

Bruno Vanslambrouck¹, Ignace Vankeirsbilck¹, Sergei Gusev¹, Michel De Paepe²

¹Howest, University College of West-Flanders
Electromechanics Department, Research Group of Thermodynamics
Graaf Karel de Goedelaan 5, 8500, Kortrijk, Belgium

²Ghent University-UGent
Department of Flow, Heat and Combustion Mechanics
Sint-Pietersnieuwstraat 41, 9000 Gent, Belgium

Abstract

On renewable energy installations such as biogas-, landfill gas- and bio oil engines and even at all kinds of industrial plants lots of waste heat is dissipated into the atmosphere.

On the other hand, there is a proven, commercially available technology to convert it (partially) into electricity. This is the Organic Rankine Cycle (ORC), used since several decades within f.i. geothermal plants. Applications of the same technology for waste heat recovery are rather premature.

To transfer this technology to such applications, practical research in collaboration with industry was performed with as output : technology review (used working fluids to replace water/steam, expander types...), a market overview, view on technical and economical feasibility, simulation models, comparison between the steam cycle and ORC and selection criteria, industrial case studies (landfill- and biogas engines, steel, glass, paper, automobile, chemical, clay, water cleaning....industry).

As a conclusion, ORC-projects were found being very attractive on renewable energy applications with the help of green power certificates. On non renewable industrial cases, economic feasibility strongly depends from integration costs and electricity prices.

Keywords

ORC, Organic Rankine Cycle, waste heat recovery, energy efficiency

1. Introduction

In our society there is a great demand for mechanical and electric energy. Besides renewable energy sources, such as photovoltaic panels, wind turbines and hydropower, most of our energy is being generated from thermal energy. This thermal power is in general obtained from the combustion of fossil fuels or from nuclear reaction. Depending on the application, different thermodynamic cycles have been developed in practice, leading to serviceable machines and processes. Commonly used are : combustion engines (petrol, gas, diesel), gas turbines, steam turbines (Clausius-Rankine cycle as a specific variation). These processes always use a high temperature heat source and typically achieve a cycle efficiency between 25 and 55%. Still a lot of waste heat is being released in these cycles, often on relatively high temperatures (combustion engines, gas turbines). In case this waste heat can be recovered usefully in a CHP

Corresponding author: bruno.vanslambrouck@howest.be,

Tel.: +32 56241227, Fax: +32 56241224

(combined heat and power) installation, a high fuel utilization ratio can be realized (80-100% ref LHV).

If this heat can't directly be recovered in a useful thermal application locally, it would be beneficial to have a process that transforms this heat into additional mechanical work or electricity. Even low temperature industrial waste heat, that can't be recovered otherwise, could still have a practical application in this way. A suitable thermodynamic cycle to this purpose is the Organic Rankine Cycle (ORC). This cycle resembles the classic steam cycle commonly used in thermal power stations. If only a heat source on low temperature is available or in small scale applications, it could be advantageous to replace water/steam by a suitable organic medium. This technology is already commercially available and has been successfully applied in the past decades to generate electricity from geothermal wells (75-300°C). ORC systems are also effectively applied in relatively small scale biomass power plants.

This paper results from a practical oriented, and governmental funded, research project (TETRA, or Technology TRAnsfer). The objective of this project is to make the ORC technology widely known in Flanders and to eliminate any barriers in its practical implementation.

No research in optimizing the ORC system itself has been performed, but some case studies have been elaborated to prove the availability and applicability of this technology in Flanders. Initially, the focus was on renewable energy sources because of the financial support with green certificates. Recently more and more low-priced ORC units became available, so in a second research project some case studies on non-renewable, industrial waste heat sources have been investigated. A test rig with a unique 11 kWe ORC has been built as a demonstration and testing facility.

This paper includes a description of the ORC-technology, its applicability, used expander types, a comparison with the classical steam cycle and some economic considerations. Also the test facility is briefly described.

2. The (Organic) Rankine Cycle

Figure 1 shows the main components of a steam cycle in a thermal power plant : boiler (1), steam turbine (3), generator (4), condenser (6), cooling tower (7) and feed pump.

This thermodynamic cycle is being applied successfully in large thermal power stations, where it is commonly adopted as proven technology, and for which the advantages to the use of water as a heat transport medium outweigh the few drawbacks.

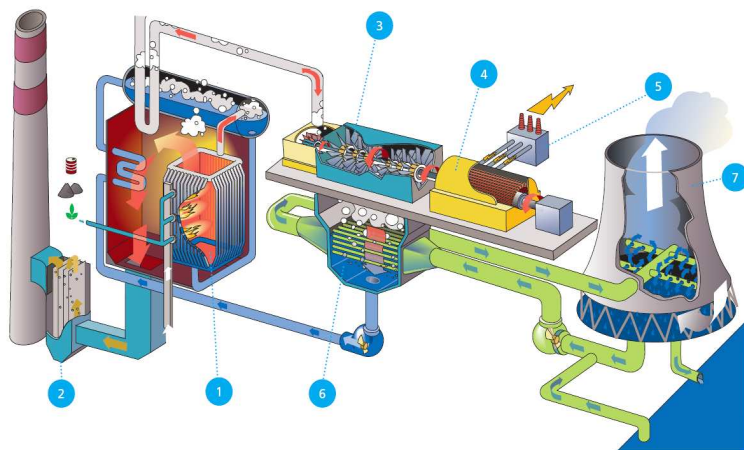

Figure 1 : Conventional Rankine Cycle in a thermal power station (source: Electrabel)

The disadvantages to the use of water/steam can best be explained by considering the T-s diagram of a simplified steam cycle as presented in Figure 2. This steam cycle is frequently used in small scale power installations up to a few MW_e and compared to this steam cycle the

2nd European Conference on Polygeneration – 30th March -1st April 2011 – Tarragona, Spain
 ORC seems to be a potential alternative. The main disadvantages to the use of water as working medium are :

- For a condensing temperature around ambient temperature, a very low pressure is required, f.i. $T_{\text{cond}} = 45^{\circ}\text{C}$ requires a p_{cond} below 0,1 bar. A low pressure implies a low density or a high specific volume at the outlet of the steam turbine and condenser and thus a big diameter for the final turbine stage and condenser.
- Due to the high pressure ratio between in- and outlet of the steam turbine, the design of the turbine becomes more complex and multiple stages are required.
- To avoid the formation of moisture in the final stages of the steam turbine, the steam needs to be superheated to higher temperatures. These high temperatures have their impact on the design and material choice for the turbine and heat exchangers.
- Water also has a high evaporation heat, and thus demands a heat source that can deliver a lot of thermal energy on a high temperature level.

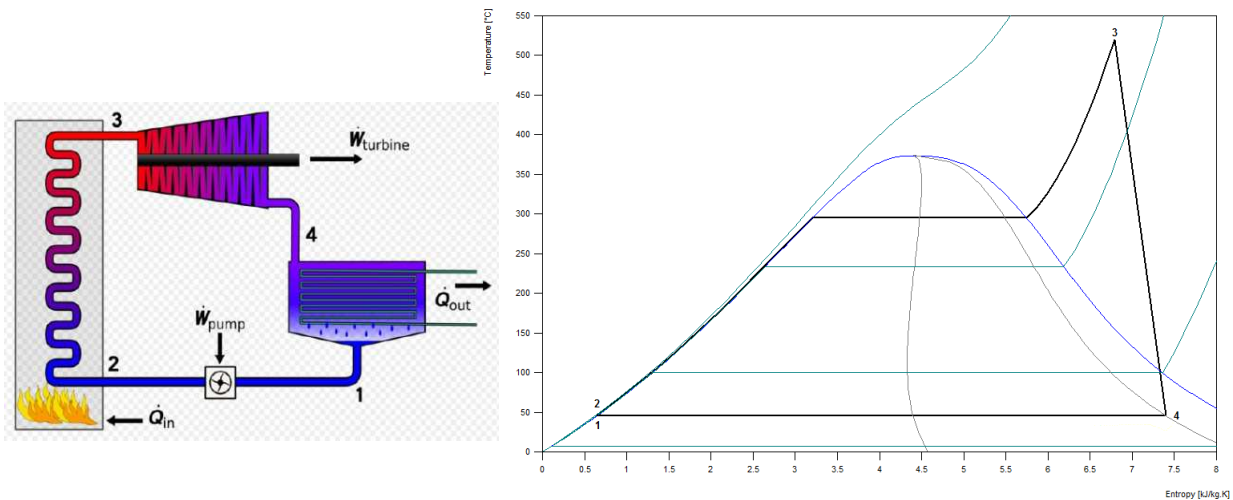

Figure 2 : T-s diagram of simplified steam cycle

From these drawbacks can be concluded that the applicability of water/steam is restricted when an industrial waste heat source on relatively low temperatures is considered. A better alternative in these cases is the Organic Rankine Cycle (ORC). The ORC is based on the same thermodynamic principles and the same components as a conventional steam cycle are used (heat exchanger, expander, condenser, feed pump), only a different working medium is applied. Mainly organic fluids, like refrigerants (R245fa), toluene, (cyclo)-pentane or silicone oils are used. These fluids are characterized as dry fluids and have some interesting properties compared to water/steam[1-4].

As an example the T-s diagram for toluene is represented in Figure 3. (Diagram made with Fluidprop [5]). Dry fluids, like toluene, are characterized by a positive slope of the saturated vapour curve in a T-s diagram. Due to this characteristic dry fluids don't need to be superheated because after expansion the saturated vapor remains in the superheated area.

The main advantages of organic fluids compared to water/steam can be summarized as follows:

- The organic fluids in an ORC can already be used at a much lower evaporation temperature and pressure.
- Superheating is not required, although in practice a small degree of superheating is applied in some ORC-units.
- The evaporation heat of organic fluids is approximately 10x smaller compared to water.

This all results in less higher demands to the temperature level of the heat source. Less heat on a high level is needed to evaporate the fluid, so low grade industrial waste heat can also be used as a heat source in an ORC. The minimum temperature at which an ORC can be applied starts

at about 55°C. Obviously, the cycle efficiency strongly depends on the temperature difference between evaporation and condensation. The smaller the temperature difference, the lower the cycle efficiency will be.

Also the selection of the organic fluid for a given application (heat source) is a key issue. Refrigerants are only efficient in use with a low grade heat source. For waste heat on a high temperature level, f.i. exhaust gases of a combustion engine, other organic fluids such as toluene or silicone oils are used and a cycle efficiency of 20 – 25% can be achieved with these ORC-units.

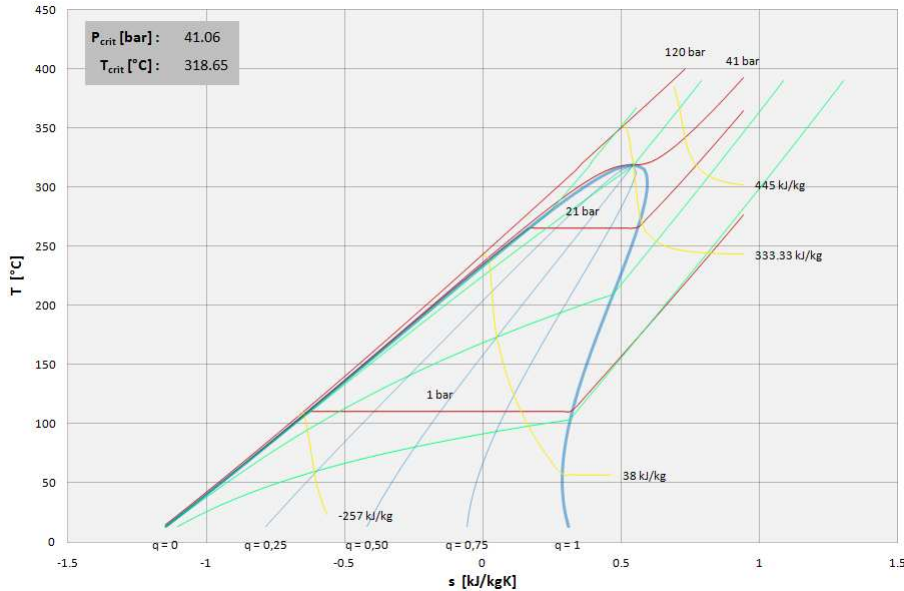

Figure 3 : T-s diagram Toluene

Figure 4 represents a schematic flow of an ORC-installation and the resulting cycle in a T-s diagram :

- 1-2 : expansion to condenser pressure
- 2-3 : cooling down superheated vapour in regenerator at constant pressure
- 3-4 : condensation
- 4-5 : pressure increase by feed pump
- 5-6 : preheating ORC fluid in regenerator
- 6-1 : preheating and evaporation by external heat source

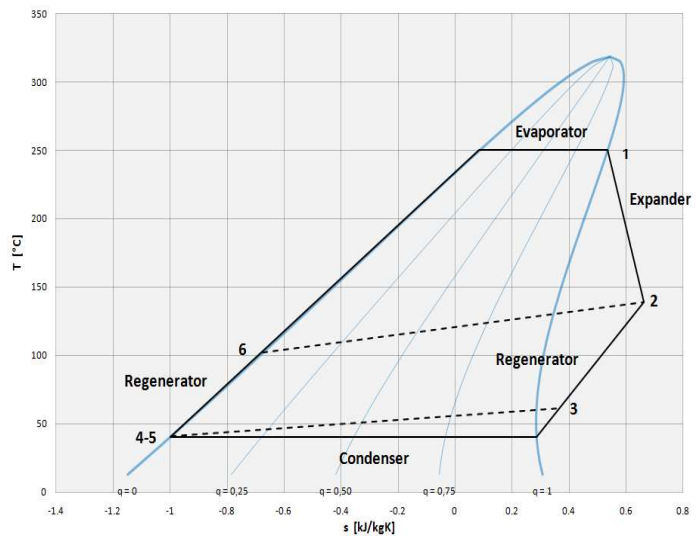
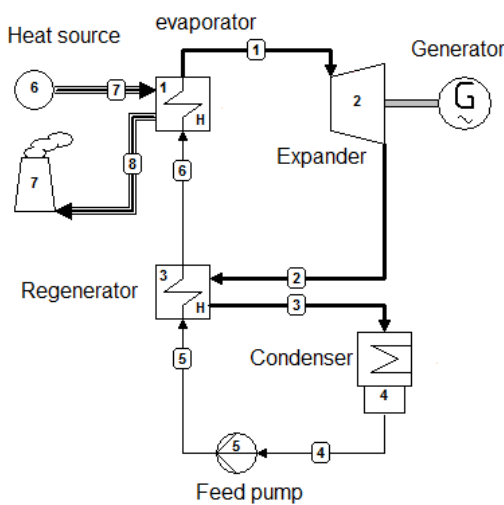

Figure 4 : Lay-out and T-s diagram of ORC with regenerator

Due to the characteristics of dry fluids, the vapour remains largely superheated after expansion. This fact has a negative influence on the cycle efficiency, because the superheated vapour first has to be cooled down in the condenser. In this manner also the heat content of the superheated vapour is dissipated in the condenser, besides the condensation heat itself. Therefore a regenerator is often used to increase the cycle efficiency. The superheated vapour is first cooled down towards condensation temperature in the regenerator by preheating the liquid fluid after the feed pump. A drawback of a regenerator is that an external waste heat source can't be cooled down as deeply as without a regenerator.

Due to its characteristics, an ORC system can be efficiently applied to recover waste heat in exhaust gases. Often a higher net electrical yield can be achieved with an ORC system compared to a steam cycle. Table 1 shows the simulation results for an arbitrary waste heat flow with a maximum temperature of 350°C, and a thermal power of 3000 kW_{th} (when cooled down to 120°C). In Figure 5 the corresponding temperature profiles and pinch points are represented for an ORC- and steam cycle. The ORC is simulated with regenerator and as an organic fluid the silicone oil hexamethyldisiloxane (MM) is used.

Table 1: Results efficiency waste heat recovery

		ORC	Steam	
P_{evaporator}	[bar]	14	12	18
η_{i turbine}	[%]	75	75	74
T_{sup}	[°C]	234	300	329
P_{th recover}	[kW _{th}]	2509	2371	2121
P_{gen,nto}	[kW _e]	522	500	473
η_{gen,nto}	[%]	20.8	21.1	22.3

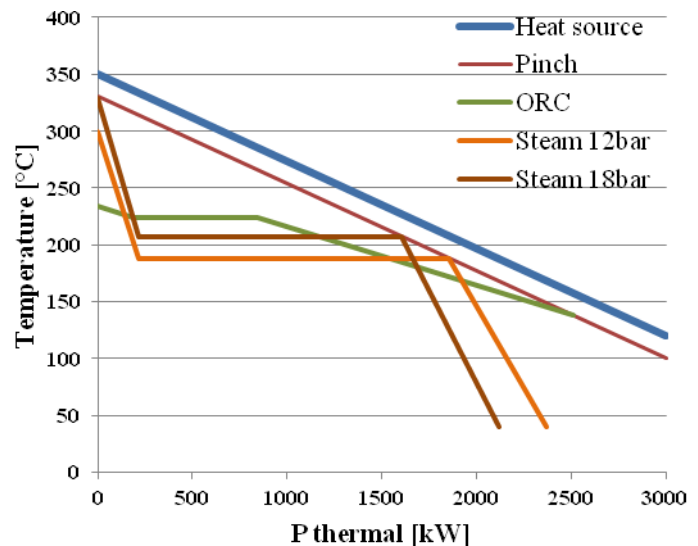

Figure 5 : Comparison temperature profiles and pinch point

As shown in Table 1, more waste heat can be recovered by the ORC (P_{th recover}). In spite of the lower cycle efficiency compared to a steam cycle, a higher net electric power at the generator can be obtained with an ORC. In Figure 5 the corresponding heating profiles are drawn. The ORC system requires less thermal heat to evaporate the organic fluid compared to the steam cycle, and as a result a higher evaporation temperature can be applied. On the other hand, the steam cycle requires a higher superheating temperature depending on the evaporation pressure used. For a steam cycle the combination of the evaporation pressure and superheating temperature is often the restricting factor in low grade waste heat recovery applications. Which cycle, steam or ORC, gives the best results strongly depends on the temperature profile of the waste heat source and should be further investigated case by case. This comparison is one of the topics in our current research project.

3. ORC applications

The ORC-technology can be applied in a broad range of situations. Essentially, every low grade heat source starting at about 55°C can (technically) be used as an input heat source to an

ORC. A survey of possible application areas has already been given by Quoilin et al. [7] and some will also briefly be presented in this paper.

3.1 Industrial waste heat recovery

In the industry there still are plenty of waste heat flows on relatively low temperature that are dissipated to the environment by cooling towers or in stacks. Some of these heat sources are reused in other on-site applications or are used for district heating. However, when there is no direct application for this thermal waste heat, it could be used to generate electric power by means of an ORC.

One of the first waste heat power generating plants using the Organic Rankine Cycle was implemented at Heidelberg Cement in Lengfurt (Germany), where the clinker cooler exhaust air at ca 270°C serves as a heat input to an ORC. A description of this ORC plant has been reported by Baatz et al. [8] and the long-term operating experience by Claus et al. [9]. The aim of this project was to generate 1,1 MW net electrical power and reported are an availability higher than 97% and a high flexibility with heat flows which lie between 67% and 110% of the design capacity and exhaust air temperatures varying between ca 165 and 305°C. This report proves the reliability and the high flexibility of the ORC technology.

On the incinerator for domestic waste at MIROM in Roeselare, Belgium the waste heat in the exhaust gases is used for district heating. Because of a significant overcapacity an ORC was installed to generate electric power from it. This system is being monitored and is used as a case of experience in our research project. Figure 6 shows a schematic flow of this system. The exhaust gases heat up a water circuit at 180°C that is used by priority as an input to the district heating and the surplus of hot water is directed to the ORC system. This ORC reaches an efficiency of 16-17% and generates 2,5 MW net electrical power. Also this system shows a remarkable flexibility.

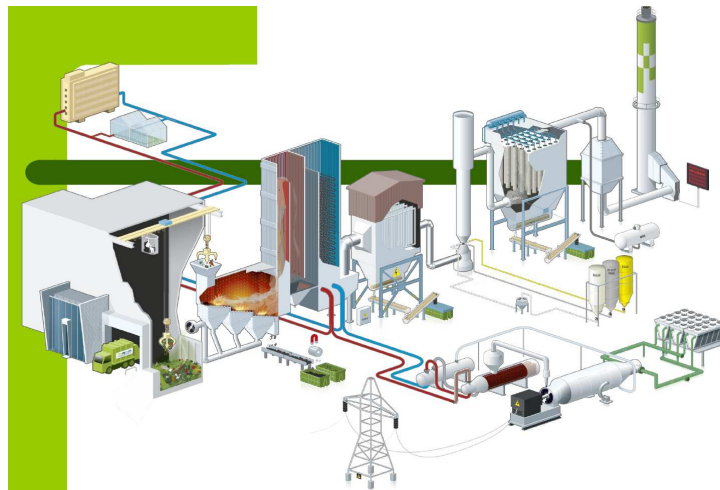

Figure 6 : Schematic flow incinerator MIROM, Belgium (Source : MIROM)

This ORC reaches an efficiency of 16-17% and generates 2,5 MW net electrical power. Also this system shows a remarkable flexibility.

Other areas of application for ORC systems in industry can be found on solvent containing waste gas afterburners (VOC or Volatile Organic Compound control), gas flares in process industry, poor quality gases and landfill gas, low pressure steam, process cooling water, melting furnaces...

3.2 Internal combustion engines (ICE) and gas turbines

A lot of combustion engines are used in CHP applications. Besides the electric power generation, the waste heat of the engine is used for heating purposes (f.i. greenhouses). Internal combustion engines and gas turbines typically have a thermal efficiency in the range of 20 to 50%. A greater part of the fuel energy is being dissipated in the exhaust gases and jacket cooling. The exhaust gases often have a temperature level above 300°C and thus are very suitable as input source for an ORC system. Also the jacket cooling, with temperatures around

2nd European Conference on Polygeneration – 30th March -1st April 2011 – Tarragona, Spain
 90°C, can be used or integrated in an ORC system. This manner the total efficiency of the combined system (engine + ORC) can substantially be improved. Approximately 10% supplementary electric power can be generated from the same fuel input. Figure 7 shows a general scheme for a combined CHP- and ORC installation.

There are also ORC systems available on the market that can be operated as a CHP unit. These systems usually condensate on a higher temperature level, and the condenser heat is used to produce hot water. Because of the higher condensation temperature, these systems have a slightly lower electrical efficiency.

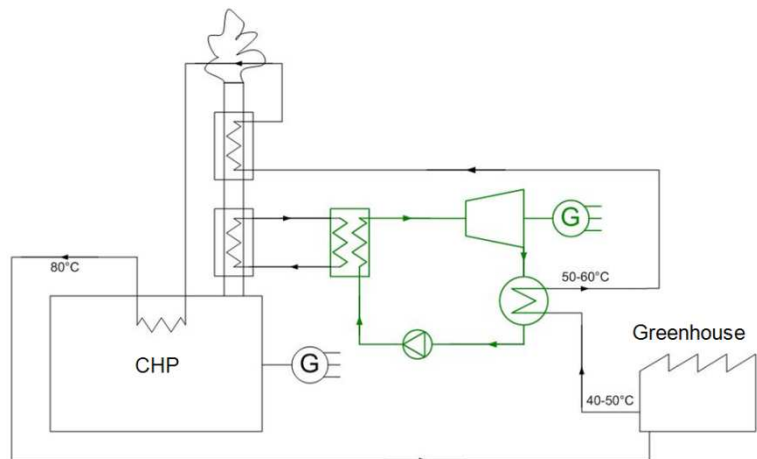

Figure 7 : ORC integrated within a CHP installation

In the automotive industry several research projects on the integration of an ORC on the exhaust gases of the car engine are in progress. Applications for the ORC can be found in combination with the hybrid technology or to generate additional mechanical power. Also small scale ORC's of few kW, can be used to drive directly the airco compressor.

3.3 Renewable energy power plants

The ORC technology can successfully be integrated into renewable energy power plants, such as solar, geothermal and biomass fired power plants.

In solar power plants the solar energy is being concentrated by parabolic troughs and used as a input heat source to a power cycle. Besides the steam cycle, also the Organic Rankine Cycle can be applied profitably to generate electric power, as being reported by Price et al. [10]. Another solar-ORC application is the desalination of sea water that has been investigated by Tchanche et al. [11].

Geothermal energy is widely available in a broad temperature range, and the ORC technology is already applied for several decades on these heat sources. For low to medium temperature heat sources, the ORC is a favourable power generation cycle (ENGINE workshop 5[12]).

On biomass fired boilers often an ORC is preferred because of the lower operation pressure and the less stringent legislation compared to a steam cycle. Figure 8 shows a schematic chart of an ORC based CHP installation on a biomass fired boiler. The condenser heat can be used in (biomass) drier applications or as district heating.

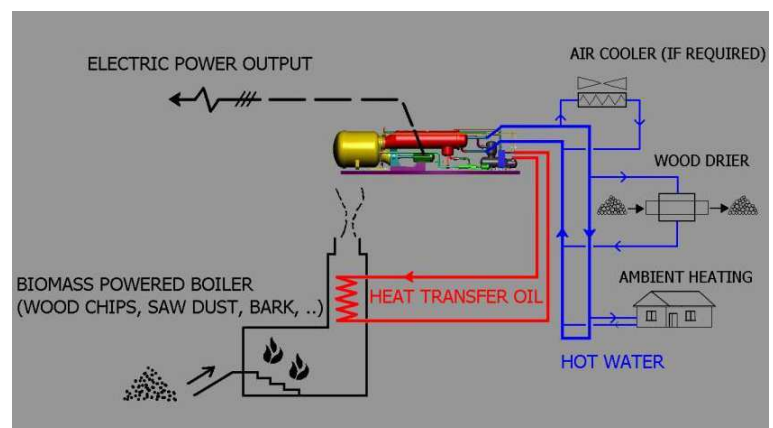

Figure 8 : Schematic chart of ORC based CHP installation (Source : Turboden)

4. ORC expander technology

4.1 Classification parameters

There are several possibilities to classify the very different versions of ORC's. In a classification according to the power range, micro-systems (0,5-10 kW_e), small systems (10-100 kW_e), medium range (100-300 kW_e) and large systems (300 kW_e – 3 MW_e or more) can be distinguished. The required heat source temperature is an other relevant parameter by which ORC's can be categorized : low temperature systems (55° tot 150°C), medium temperature (150°-300°C) and high temperature ORC's (above 300°C). According to the condenser temperature : ambient temperature and temperature levels between ca 50° and 90°C (CHP-mode) can be distinguished. The used expander technology is also an important parameter but is often linked with other parameters such as power and temperature range.

Also the “maturity of the technology” could be a parameter. Despite their announcement on the internet or through other channels, often with changing characteristics, prices, etc..., the availability of several ORC units isn't always clear. Some are still unavailable despite 8 years of “promotion time”. Classifications : “available with different known references”, “premature commercialization after (successful) tests”, “experimental” and “rejected”.

4.2 Classification according to the used expander technology

This classification is the most comprehensive to become an overview of the “state of the art”.

4.2.1 Turbine based ORC's

Because of their dedicated design, the highest efficiencies can be achieved with these turbines. They are mainly applied in high temperature applications.

As an example, Figure 9 shows the turbine used by Tri-O-Gen (The Netherlands). This ORC uses toluene as a working fluid and needs a heat source higher than 350°C because the turbine's inlet temperature is 325°C (some superheating is applied). This ORC is well adapted to the use of exhaust heat of combustions engines. Several references are known.

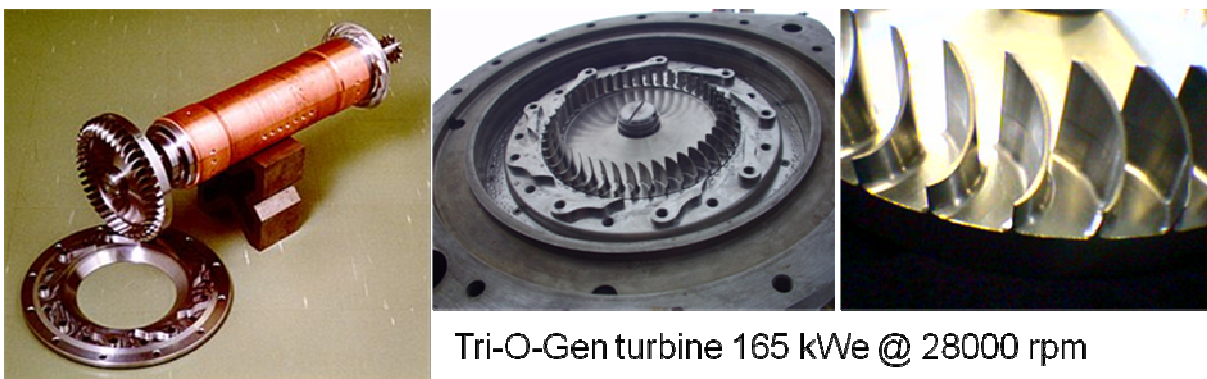

Figure 9 : Turbine used by Tri-O-Gen (source : Tri-O-Gen)

Some other well established manufacturers using specific designed turbines are Turboden, Ormat and Maxxtec.

4.2.2 Reversed centrifugal chillers

Some ORC's are derived from cooling equipment. It suffice to reverse the cooling cycle in the equipment to obtain an ORC. Best known example of this type of ORC is the PureCycle 280 from Pratt & Whitney (Figure 10). To transform a centrifugal chiller into a power cycle, the

2nd European Conference on Polygeneration – 30th March -1st April 2011 – Tarragona, Spain
 compressor has to be reversed to a turbine, the motor has to be replaced by a generator, and the expansion valve has to be substituted by a pump. By keeping R134a as an organic medium, a very low temperature ORC unit is obtained (used in geothermal power plants in Alaska where a very low condenser temperature can be achieved). When using R245fa as a working fluid, this type of ORC can be optimized for waste heat sources between 90° and ca 140°C, as the evaporating temperature is around 122°C at a maximum operating pressure of 20 bar.

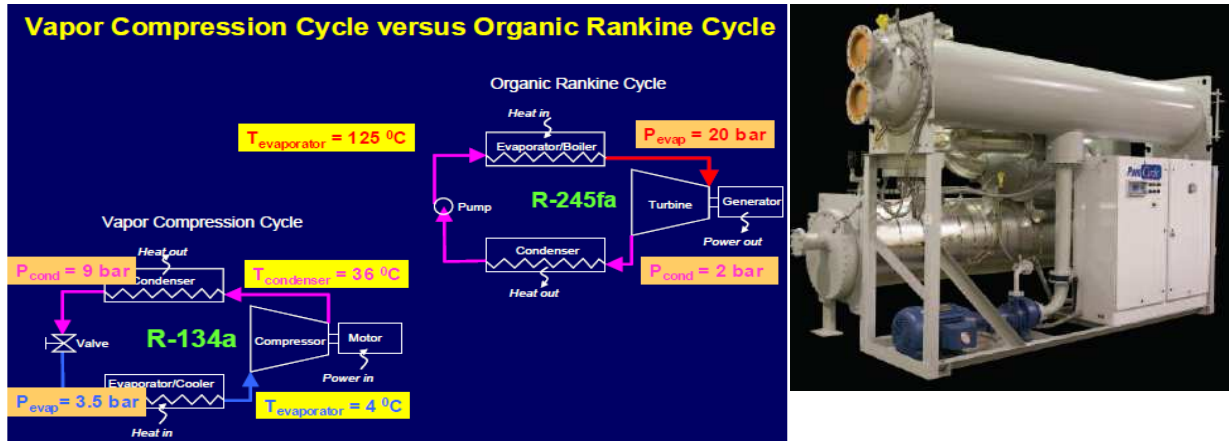

Figure 10 : ORC derived from a centrifugal chiller (source: Pratt & Whitney)

The advantage of this type of ORC is a rather low price and a high reliability. Almost all used components are proven technology, and principally the installation and maintenance can be performed by current constructors and chiller technicians.

4.2.3 Mono screw - , Twin screw - , and Lysholm expanders [13,14]

These expander types are derived from volumetric compressors by reversing them. The Lysholm compressor was invented in 1934 for use as a supercharger for combustion engines. Lubrication and avoiding friction caused by thermal expansion are the main issues when using such expander types. These ORC's can also be classified as low temperature ORC's, as the nominal operating temperature should not exceed too much the nominal operating temperature of the compressor mode.

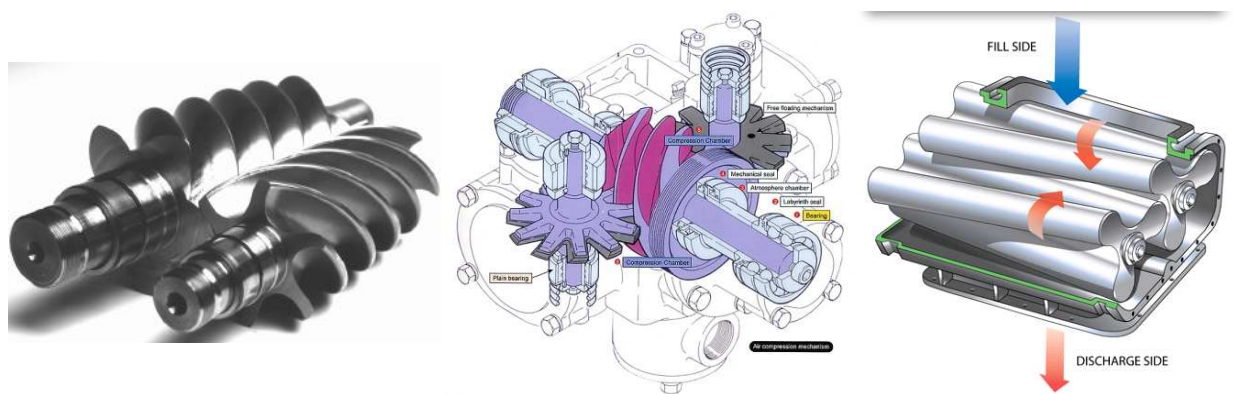

Figure 11 : Twin screw, mono screw and Lysholm expander

These expanders are very robust and can withstand fluid drops at the inlet. Even pure fluids can be “expanded”. The points 2, 3, 4 and 5 in Figure 13 are all acceptable as inlet conditions to the expander.

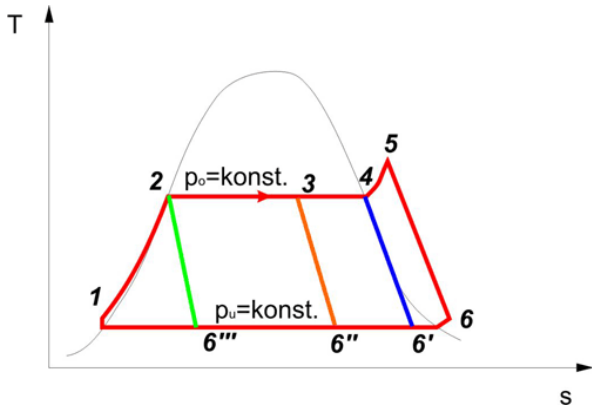

Figure 13 : Possible (steam) cycles using screw expanders



Figure 12 : Mono Screw 50 kWe ORC of BEP Europe

Twin screw compressors are available on the market in the MW-range, so ORC's in this power range can also be expected to be available. Projects with 250 kW-units have already been implemented. The main manufacturers using this technology are : Electratherm (twin screw expanders), BEP Europe (mono- or Z-screw expanders) and Opcon (Lysholm expanders).

4.2.4 Scroll expanders

Scroll compressors are also widely used in cooling and airco equipment and can easily be reversed to act as an expander. Some ORC developments using this type of expander are known [15]. The power range for scroll expanders is limited to about 30 kW_e, and commercialization of this ORC type is still premature. Eneftech and Energetix are the main constructors using this technology.



Figure 14 : Scroll expander

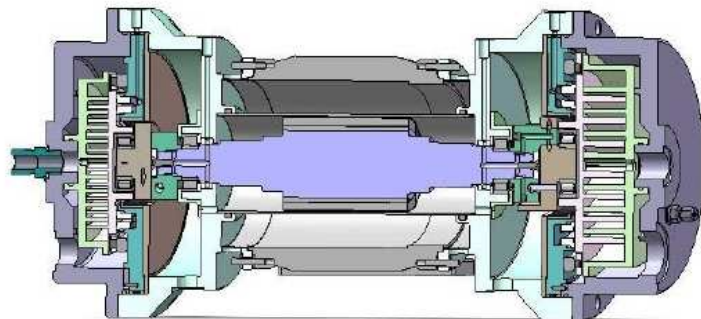

Figure 15 : 2-stage scroll expander (Eneftech)

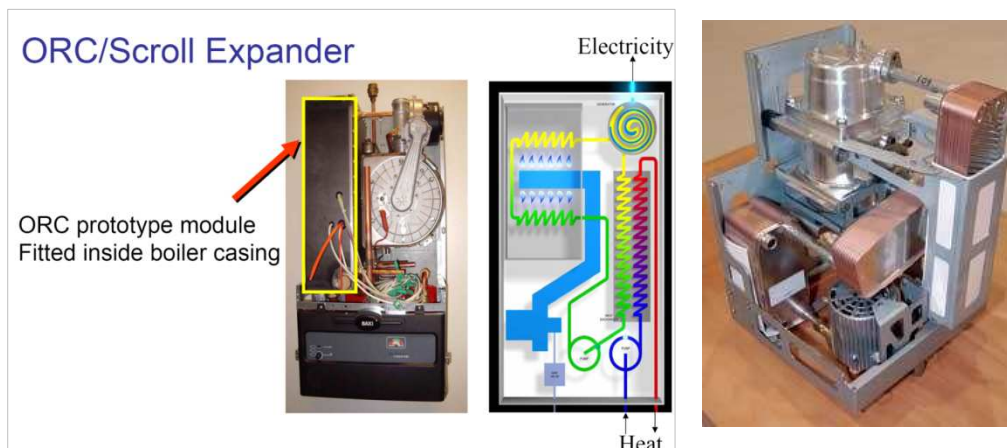

Figure 16 : Scroll expander based residential μ -CHP (Energetix-Daalderop)

4.2.5 ORC's derived from gas expanders

Gas expanders, as produced by f.i. Atlas Copco can also be applied in ORC installations. As they are promoted for such use, WOW Energies (USA) has already (some ?) ORC references based on this technology.

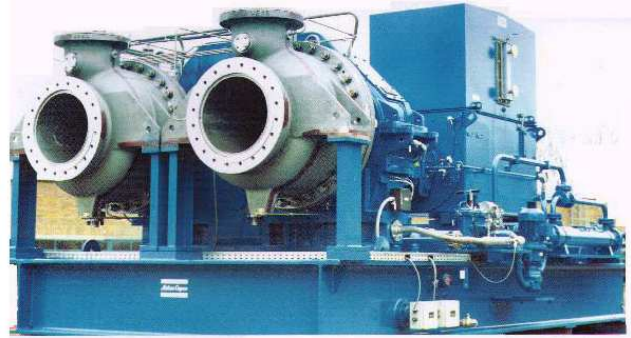

Figure 17 : 2-stage gas expansion turbine (Atlas Copco)

5. Some economical information

New energy saving technologies can only become appealing to invest if they offer a favourable cost/benefit balance. A second possibility is when they get a strong financial support by the government, as is the case with photovoltaic panels. But other promising technologies such as Stirling engines or fuel cells disappear to the background just by lack of this support.

The economical balance of an ORC project isn't always profitable. Main determining factors to the investment costs are : module size, integration cost and – complexity, profits of generated electricity, federal support (f.i. when producing electricity from a renewable heat source).

Price data for a lot of ORC modules is known within our research group and is used when performing case studies. Because of the confidentiality, a complete overview can't be published in this paper. But following indications should demonstrate that there are feasible opportunities for ORC applications.

Low temperature ORC's become available from about 1350 €/kWe for a 250 kW-unit to 2200 €/kWe for 50 kW-units. Turbine based ORC's (high temperature) range from 1000 €/kWe for a 2 MW-unit, to 2000 €/kWe for a 500 kW-unit and up to 3000 €/kWe for a 150 kW-unit. This are all average prices based only on the ORC module prices. Installation costs are very variable and are strongly site and application dependent. For waste heat recovery applications, these can range from 50% (higher power range) to 100 % (lower power range) of the ORC module's cost.

Based on calculations made in our case studies, a payback time of about 3 years, or even less, can be found on renewable energy applications (IRR of 25% or more), due to the federal support of green certificates (about 110 €/MWe in Flanders).

Depending on the project conditions (electricity price, integration cost, operating hours, investment support...) the economical balance can also be acceptable (IRR>15%) for non renewable, industrial applications. Also third party financing can create opportunities.

6. ORC test facility at Howest

An electric thermal oil heater was selected as a heat source to reach a maximum temperature of 350°C. The heater consists of 10 heating elements of 25 kW in parallel. The heat provided to the ORC unit being tested, can be adjusted continuously between 0 and 250 kW_{th}. Only 1 heating element is continuously variable, the other elements are on/off controlled. Fast and large changes in heat supply can be realized to investigate the dynamic behaviour of the ORC. A layout of our test facility is shown in Figure 18 and Figure 19.

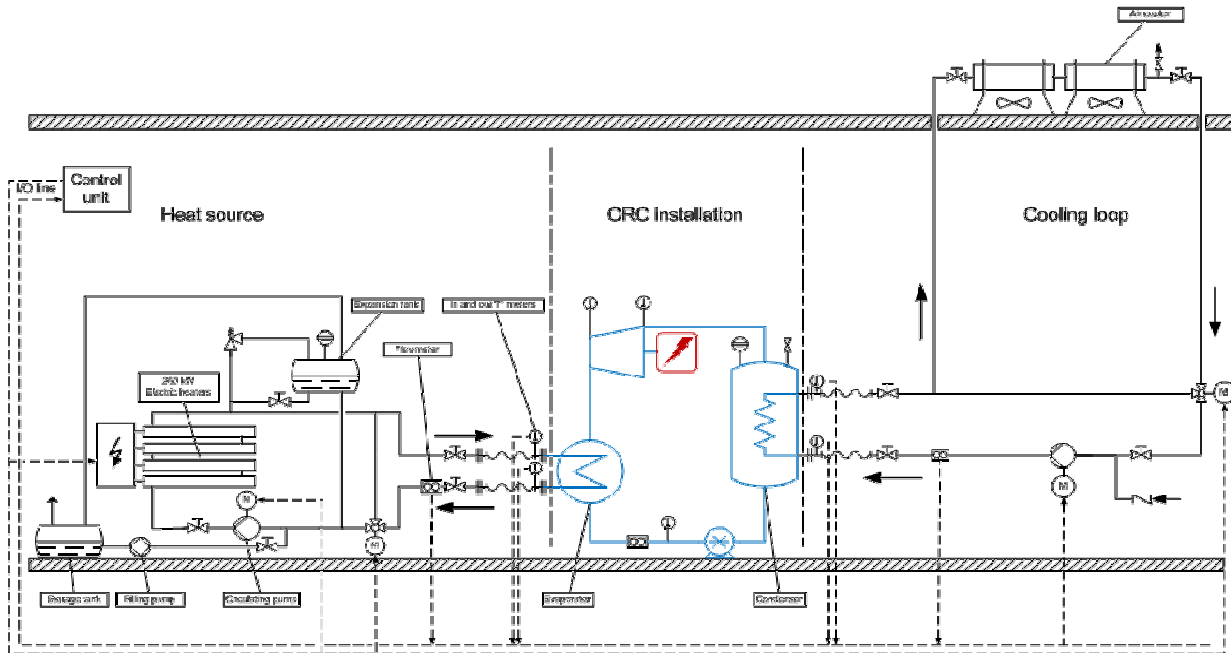

Figure 18 : Layout test facility Howest

Heat source:

Maxtec electric thermal oil heater



10 x 25kW , GC-Heat
 Electric power: 250 kW
 T.O. flow: 14 m³/h
 Max. temp.: 340°C



Panel PC477C
 WinCC flexible RT 128 tags

ET2005 DP slave
 10 DI / 10 DO
 2 RTD
 3 Direct starters 0,9kW
 1 Reverse starter 0,9kW
 Drive 2,2kW



Cooling loop

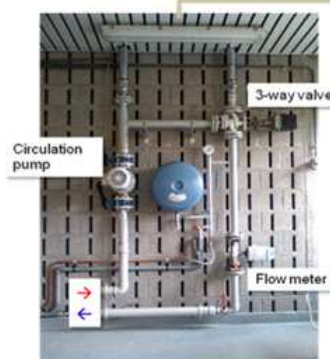

- water + glycol
 - max 20 m³/h
 - max 120°C

Figure 19 : Heat source, cooling loop, process control and monitoring, 11 kW_e ORC

The cooling loop consists of an air cooler on the rooftop, a circulation pump and a bypass valve. The condenser temperature can be set from slightly above the ambient temperature up to ca 120°C. This allows to simulate the cogeneration working mode and to test the influence of the cooling temperature on the performance and cycle efficiency. A small inside cooler is also

2nd European Conference on Polygeneration – 30th March -1st April 2011 – Tarragona, Spain present when testing smaller ORC units. All process parameters and energy flows are measured or can be calculated from measurement data. A data-acquisition and control unit (with PLC and touch screen) is integrated to achieve an accurate process monitoring and a robust control.

The power range of the ORC units that can be tested or demonstrated with our facility is restricted due to the limited capacity of our heat source (max. 250 kW_{th}). ORC units, up to 40 kW_e (at high heat source temperatures 200-350°C) or 20 kW_e (at low heat source temperatures 80 – 180°C) should fit on it. This unique test facility is adapted to perform all kind of tests :

- modified cycles (2 stage cycles, supercritical cycles , with/without reheating, etc...)
- performance and sensitivity tests
- comparison of different working fluids
- dynamic behaviour with fast or slow alterations in temperatures, heat load or mechanical load,
- behaviour and efficiency tests under part load conditions,
- subcomponent tests, f.i. heater/evaporator, condenser, expander, feed pump, generator, recuperator effectiveness, etc....

On the same test rig also other technologies such as absorption cooling, (high temperature) heat pumps, Thermo Acoustic Generators, etc... can be tested or demonstrated.

7. Conclusion

In this paper a general description of the steam cycle and organic Rankine cycle has been presented in short, and some of the advantages and disadvantages of the ORC compared to a steam cycle have been discussed. From the simulations made in this paper can be concluded that an ORC unit is a feasible and efficient alternative to a steam cycle, certainly when a low grade waste heat source is considered.

A brief overview of the application areas for ORC installations has been given and demonstrated by some examples of implemented installations on industrial waste heat. These implementation examples proof the reliability and maturity of this technology. A key issue in these installations is the type of expander. The different types used in an ORC unit have been listed and discussed. Finally some economic considerations and arguments in favour of the ORC have been given.

8. Nomenclature

E_{evap}	: Evaporation heat [kJ/kg]	T_{sup}	: superheating temperature [°C]
s	: entropy [kJ/kgK]	$T_{\text{in turbine}}$: inlet temperature turbine [°C]
h	: enthalpy [kJ/kg]	η_{cycle}	: cycle efficiency [%]
p_{crit}	: critical pressure [bar]	$\eta_{\text{gen,nto}}$: net cycle efficiency [%]
p_{evap}	: evaporation pressure [bar]	$\eta_{\text{i pump}}$: isentropic efficiency pump [%]
p_{cond}	: condenser pressure [bar]	$\eta_{\text{i turbine}}$: isentropic efficiency turbine [%]
T	: temperature [°C]	P_{th}	: thermal power [kW _{th}]
T_{crit}	: critical temperature [°C]	$P_{\text{gen,nto}}$: net generator power [kW _e]
T_{cond}	: condenser temperature [°C]	$P_{\text{th, reco}}$: recoverable thermal power [kW _{th}]
T_{evap}	: evaporation temperature [°C]		

9. Acknowledgements

The authors wish to acknowledge the financial support of IWT Flanders to this work (IWT is the government agency for Innovation by Science and Technology).

Also the support and the use of the simulation software Fluidprop [5] and Cycle Tempo [6] developed by Delft University of Technology, The Netherlands is gratefully acknowledged.

10. References

- [1] P.J. Mago, L.M. Chamra, K. Srinivasan, C. Somayaji, 2008, “An examination of regenerative organic Rankine cycles using dry fluids”, *Applied Thermal Engineering*, vol. 28, Jun. 2008, p. 998—1007.
- [2] T. Hung, 2001, “Waste heat recovery of organic Rankine cycle using dry fluids”, *Energy Conversion and Management*, vol. 42, Mar. 2001, p. 539—553.
- [3] B. Liu, K. Chien, en C. Wang, 2004, “Effect of working fluids on organic Rankine cycle for waste heat recovery”, *Energy*, vol. 29, Jun. 2004, p. 1207—1217.
- [4] G. Angelino, P. Colonna di Paliano, 1998, “Multi-component Working Fluids For Organic Rankine Cycles (ORCs)”, *Energy*, vol. 23, Jun. 1998, p. 449—463.
- [5] P. Colonna, T.P. van der Stelt, 2004, FluidProp: a program for the estimation of thermo physical properties of fluids, Energy Technology Section, Delft University of Technology, The Netherlands (www.FluidProp.com).
- [6] Simulation software Cycle-Tempo Website: <http://www.Cycle-Tempo.nl>
- [7] S. Quoilin, V. Lemort, 2009, “Technological and economical survey of Organic Rankine Cycle systems”, 5th European conference : economics and management of energy in industry”, April 14-17, 2009, Vilamoura, Portugal.
- [8] Baatz E., Heidt G., 2000, “First waste heat power generating plant using the Organic Rankine Cycle process for utilizing residual clinker cooler exhaust air.”, *ZKG International*, vol. 53, No 8, p. 425-436.
- [9] Claus W., Kolbe T, 2002, “Long-term operating experience with the ORC plant for low temperature power generation at the Lengfurt works.”, *ZKG International*, vol. 55, No 10, p. 78-86.
- [10] Price H., Hassani V., 2001, “Modular Trough Power Plants”, “Proceedings of Solar Forum 2001, Solar Energy : The power to choose”, April 21-25, 2001, Washington DC, USA
- [11] Tchanche B.F., Lambrinos Gr., Frangoudakis A., Papadakis G., 2010, “Exergy analysis of micro-organic Rankine power cycles for a small scale solar driven reverse osmosis desalination system”, *Applied Energy*, vol. 87, April 2010, p. 1295–1306
- [12] ENGINE WS5, 2006, “Workshop 5 : Electricity generation from enhanced geothermal systems ”, Enhanced Geothermal Innovative Network for Europe, September 14-16, 2006, Strasbourg, France, <http://engine.brgm.fr>
- [13] Leibowitz H., Stosic N., Smith I. K., 2006, “Cost effective small scale ORC systems for power recovery from low grade heat sources.”, *Proceedings of IMECE 2006 ASME International Mechanical Engineering Congress and Exposition*, November 5-10, 2006, Chicago, Illinois, USA
- [14] Steidel R. F, Pankow D. H, Brown K. A., 1983,” The empirical modelling of a Lysholm screw expander.”, *Proceedings of Eighteenth Intersociety Energy Conversion Conference*, 1983, pp 286-293.
- [15] V. Lemort, S. Quoilin, C. Cuevas, J. Lebrun, 2009, “Testing and modelling a scroll expander integrated into an organic Rankine cycle”, *Applied Thermal Engineering*, vol. 29, 2009, p. 3094–3102