

The potential of medium scale solar thermal power and solar polygeneration

Werner J. Platzer¹, Anton Neuhaeuser²

¹Dr., Head of Department Solar Thermal and Optics. Fraunhofer Institute for Solar Energy Systems ISE, Heidenhofstr. 2, 79110 Freiburg, Germany

²Dipl.-Ing., Researcher, Fraunhofer Institute for Solar Energy Systems ISE, Heidenhofstr. 2, 79110 Freiburg, Germany; email: anton.neuhaeuser@ise.fraunhofer.de

Abstract

With a study funded by the Federal Ministry for the Environment, Nature Conservation and Nuclear Safety (BMU) we could show that medium-sized solar thermal power plants in the range of 50 kW_{el} to 5 MW_{el} are an interesting option in countries with high irradiation potential [1],[2]. Especially the combined use of solar heat, cold and electricity in polygeneration can enhance the economics appreciably. Today industrial sites in remote areas mainly cover their energy demand by diesel generators and fossil burners at high running costs. Industrial companies could implement solar polygeneration systems which would lead to a significant increase of solar usage in energy production.

Keywords

Solar Polygeneration, Concentrating Solar Power, Off-Grid Systems,

1. Introduction

Large concentrated solar thermal power plants using parabolic trough and solar tower technology are getting more and more public attention in recent years. Solar thermal power may be a key component in a sustainable energy future for many regions of the world although high direct solar irradiation levels are required for an economical operation. A world wide grid is being discussed to transport electricity from source regions to demand regions, for example high-voltage direct current transmission lines are proposed for the MENA region in the Desertec concept. The number of companies being involved in Concentrated Solar thermal Power (CSP) is steadily increasing, either as manufacturers of key components, as collector developers, as project developers and planners, or as EPC-contractors. However, huge investment sums are needed even for single power stations. To build a 100 MW_{el} solar power station 400- 600 Mio. € are required. The risks for investing such sums are usually evaluated and checked thoroughly in a time-consuming process. Due to economy of scale nevertheless one tendency is to increase the size of projects, the smaller ones starting at minimum 10 MW_{el}, the larger ones exceeding already 100 MW_{el}.

The costs of solar photovoltaic (PV) systems are steadily decreasing. For large PV power stations in the MW range overall costs including cost of installation, land cost and planning

Corresponding author: Werner.Platzer@ise.fraunhofer.de

costs of about 4000 – 5000 € per kWp are reported, with even lower costs for a thin-film power plant at 3250 € per kWp [3]. Using these values for sunny sites in Southern Europe levelised electricity costs (LEC) around 20 ct/kWh are possible.

For solar thermal power stations in Spain a feed-in tariff of 27 ct/kWh provided enough incentive for project developers for power stations in the range 50 MW_{el}. However generally it is not considered economic to build solar thermal power in a range of 1 MW_{el}. Higher specific power block and planning costs together with lower efficiencies would drive LEC up. Does this mean that solar PV is generally the better and cheaper solution in this power range? The MEDIFRES study, investigated under which conditions solar thermal power may be economically the better solution. The specific advantages of polygeneration and thermal storage were the key focus of this investigation.

Whereas for electricity generation small and large power plants have the same well-known layout with solar field, optional storage, evaporator/heat exchanger and steam cycle, the integration of additional consumers of heat depends on both demand and supply side options. For solar polygeneration various cycle layouts are feasible. Depending on the required temperature levels, different positions of the heat exchangers in the cycle can be studied with our simulation model. Figure 1 shows a schematic layout of one possible system producing process steam, cooling by an absorption chiller and electricity. the Heat Transfer Fluid (HTF) coming from the collector with 300°C flows through the heat exchangers of an Organic Rankine Cycle (ORC). Additionally, process heat on a rather high temperature level of 200°C at 12 bar is available. The heat of condensation in the ORC cycle can be used in a thermally driven chiller operating at 85°C. To gain independence from solar irradiation and to extend the operating hours a thermal energy storage is also implemented.

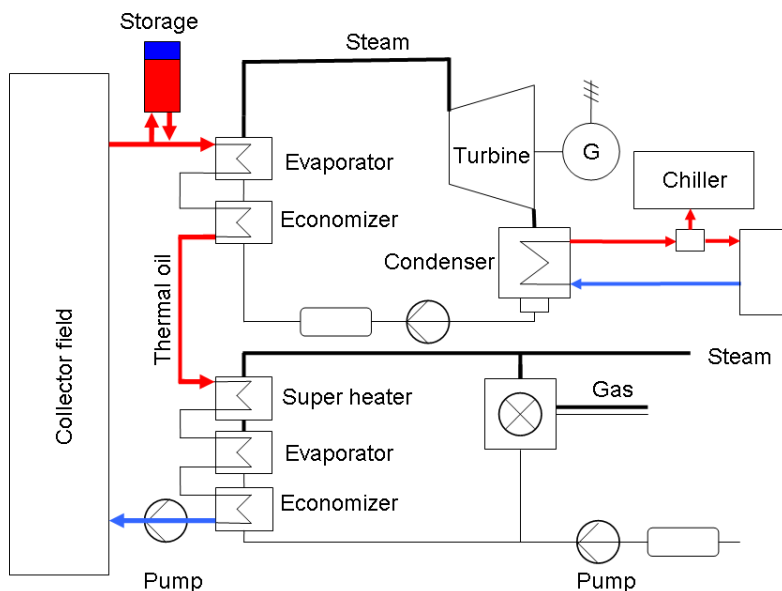

Figure 1: Possible cycle layout for solar polygeneration.

Depending on the type of solar collectors, cycle medium, heat engine, absorption chiller, cooler and process steam rather different solutions and layouts will be optimal. For instance a low-temperature ORC cycle operating with 75-90°C could use the rejected heat of a two-stage absorption chiller. On the other hand depending on the absorption chiller, it can be integrated in a solar power plant using a Rankine steam cycle using the condensation heat, or the return temperature in the solar field coming from the economizer.

3. Market overview medium temperature collectors and heat engines

For the medium temperature range a number of solar collectors, either concentrating or non-concentrating are available or in development. It may be difficult to get reliable performance data in some cases, but that should be mainly a question of time. Also a comparison of costs based on our enquiry is difficult as the maturity of different collectors varies strongly. Within our study we have updated an overview of IEA SHCP Task 33 and a revised version has been published [3].

The situation is more divers for heat engines, either using the steam Rankine cycle or other media in the Organic Rankine Cycle (ORC). There are manufacturers producing ORC-Systems for waste heat or biomass plants with years of experience, but also smaller innovative companies are developing units especially in the smaller power range below 100 kW. Also alternative engine principles, e.g. screw expanders, are being developed and not yet commercially available. Therefore the cost information is only indicative. Several enquiries were answered based on assumptions and production estimates. Nevertheless it can be said that several temperature options are available over a large power range (see Fig.2).

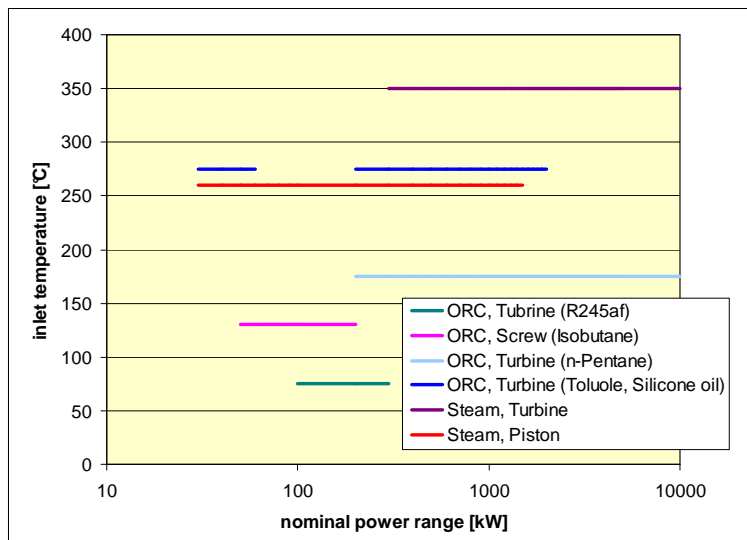

Figure 2: Overview on typical inlet temperatures and power ranges for various heat engines

4. General assumptions for case studies

As cost information was hardly available, in our approach we assumed – based on preliminary information – prices for components which should be possible to reach provided sufficient production and quantity levels can be achieved. The prices are assumed for project sizes in the 1MW and below range. Collector and power block for large scale CSP even at the moment are

below our assumptions due to scale effects. Our standard case assumptions are summarized in Table 1.

Table 1: Investment costs

Component	units	specific investment
Collector	[€/m ²]	300
Power Block	[€/kW]	1500
Storage	[€/m ³]	1000
Steam Generator Process Heat	[€/kW]	25
Absorption Chiller	[€/kW]	280

The thermodynamic calculations were run on the basis of hourly values with solar irradiation data and weather conditions. In comparison with a conventional system, the fuel savings for one year are calculated. Based on these the cash flow respectively the savings for every year of the whole life-span can be calculated. The savings are determined by calculating the net present value, i.e. summing up the discounted cash flows for each year.

Two different system types were examined: a grid connected system and an off-grid system. Both of them were compared with a conventional reference system. For the grid connected system, an existing system is assumed to be extended by a solar polygeneration unit. The reference system uses a conventional oil burner for steam generation. For cooling an electric compression chiller supplied by grid electricity is installed. These components serve as backup for the solar system. The solar system saves fuel for the steam generator and electricity for the chiller.

Plants located in remote areas without grid connection are today mostly generating their electricity on site by diesel engines. In this case the existing system consists of a diesel generator and an oil-fired steam generator. Fuel can be saved by solar electricity and heat production. An off-grid system can only use electricity if there is demand. For the simulation a load profile presented by Kaldellis [6] for an Aegean island was used. For the process heat demand a production site is assumed to have a constant load from 8 am to 6 pm. A constant cold demand is assumed to occur for 24 hours a day all year long for example in a cooling room for meat storage.

For the solar field a linear Fresnel collector oriented North-South is modelled having an optical efficiency of 67 %, using a selective absorber tube. The power block is defined by isentropic turbine efficiency of 70 %, resulting in a net efficiency (at 260°C) of 19 %, which varies on steam and condensation temperature, as well as part load. The absorption chiller is implemented as a look up table according to performance data supplied by a manufacturer.

As a base case Faro in Portugal was chosen as location for the simulations. With a direct normal irradiation (DNI) of 2197 kWh/(m²a) Faro is representative for a good location in Southern Europe.

The operation time of the system is 25 years. The discount rate is 7 percent. Further assumptions for the economic analysis are presented in Table 2 and Table 3.

Table 2: Operation and Maintenance costs

	units	value
Operation and Maintenance	[% p.a.]	2
Insurance	[% p.a.]	1

Table 3: Additional assumptions

	units	value
Feed-in-tariff (Portugal)	[€/kWh]	0.27
Electricity cost	[€/kWh]	0.10
Rate of electricity price increase	[% p.a.]	2.5
Oil price	[€/kWh]	0.08
Rate of oil price increase	[% p.a.]	8
Diesel electricity generation costs	[€/kWh]	0.31

5. Results of case studies

5.1 Comparison of photovoltaic and solar thermal plants

For pure electricity generation within the plant capacity range investigated here, photovoltaics is more economical, even if low solar field costs of 200 €/m² (which may be applicable for large projects) are assumed for CSP (see Fig. 3). For small CSP projects it is unlikely that LEC will fall below the feed-in tariff. This confirms our first conjecture on the comparative economics in favour of photovoltaics.

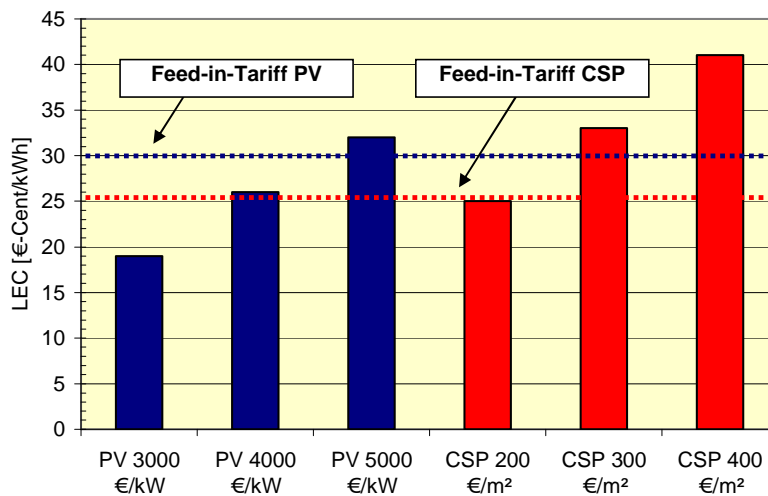

Figure 3: Levelised cost of electricity (LEC) for different solar field costs for photovoltaic power (PV) and concentrated solar thermal power (CSP) for grid-connected power systems

Surprisingly enough this changes already if off-grid systems are used. This was simulated using a demand profile. In order to satisfy the demand most of the time and to achieve a high solar fraction a storage system has to be used. Lead batteries for PV however are expensive and have a typical life time well below the project life time. Hence, they have to be replaced twice. Thermal energy storage, which can be implemented with CSP, is a much cheaper option. The internal rate of return (IRR) is therefore considerably higher for CSP (assuming financing with equity capital) compared to PV, even if low PV investment costs in the range of 3-4 €/W are assumed (see Fig. 4).

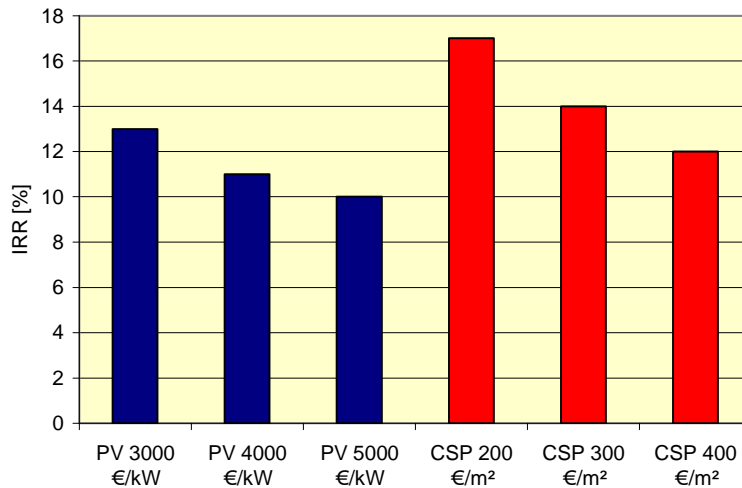

Figure 4: Internal rate of return (IRR) for equity invested in photovoltaic power (PV) and concentrated solar thermal power (CSP) in off-grid systems for different solar field costs

CSP systems are even more favourable if the project allows combined heat and power (CHP) because there is a process heat demand in a reasonable relation to the electricity demand. Comparing that to PV was calculated by assuming the low temperature process heat of 800 kW at 85°C during working hours 8-18h supplied by a flat-plate collector system for very low 200 €/m² field cost. Due to the dual use of the solar field for CHP the economics are much better than for the combination of two solar systems PV plus solar thermal collectors (see Fig. 5).

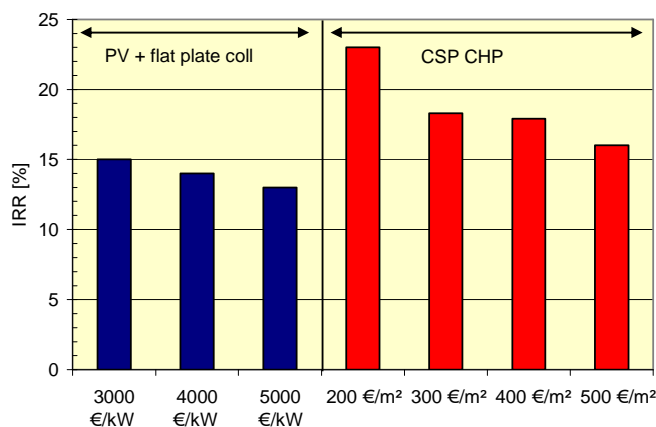

Figure 5: Internal rate of return (IRR) for equity invested in PV/Flat-plate solarthermal systems and concentrated solar thermal power (CSP) utilizing combined heat and power (CHP) for different solar field costs

5.2. Solar cooling and electricity generation

Also a combination of power generation with solar cooling is possible. Different possibilities for the integration of the absorption chiller are possible. For an off-grid system with electrical demand of 1.2 GWh/a (max. 320 kW) and specified cooling load of 500 kW we investigated the effect of various cooling load profiles and of various chiller integration options. The heat utilisation (cooling energy plus electricity divided by heat from solar field) is differing significantly among the investigated options (see Fig. 6). One of the investigated load profiles is shown in Figure 7.

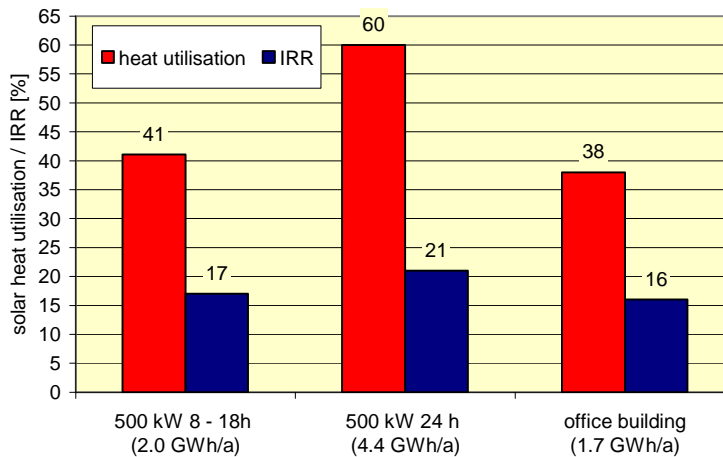

Figure 6: solar heat utilisation and internal rate of return for different cooling load profiles
 a) 500 kW during working hours 8-18h b) 500 kW 24h constant
 c) variable load for an office building (yearly demand in brackets)

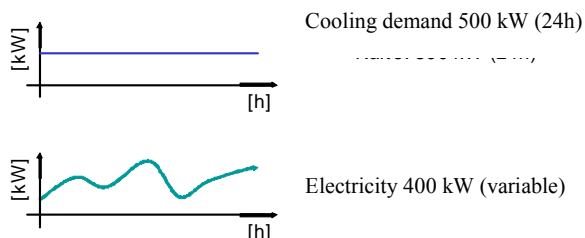

Figure 7: Demand profiles for combined cooling and power (CCP) in an off-grid industrial plant

A large cooling demand proved to be optimum for the economics of the system, which used a single-stage absorption chiller taking the reject heat of the heat engine at about 90 °C condensation temperature. For a serial connection using a double-stage chiller in the return of the solar field loop, the solar fraction for the chiller was much smaller. Important for the concept was the availability of thermal storage. A solar field size of 5700 m² was used for the optimum design having a 300 m³ thermal storage system. For comparison the Andasol molten salt storage has a capacity of 12500 m³. For the small scale CSP we calculated – within the limits of our assumptions – a capital investment of 2.5 to 3 Mio. €, which is a quite reasonable project for a single investor.

6. Conclusions

In the present study it has been shown that also Medium and Small Size Concentrated Solar thermal Power (MSS-CSP) plants from about 50 kW_{el} up to 5 MW_{el} can be economically feasible [1,2]. One prerequisite is the development of a real market and adapted products with competitive prices. This could be an opportunity for SME companies to participate in the development of solar thermal power without excessive financial risks. Simpler technology and less complex planning may help to compensate the intrinsic problem of typically higher specific costs of smaller units per kW and per collector area respectively. Also, the potential benefits of combined generation of heat, cooling and power could be utilized by smaller power stations if dimensioning of the plants take into account the heating and cooling demand profiles. The obvious market for such system lies in off-grid applications and weak-grid areas, where today commonly Diesel engines are used to supply heat and power to small production sites. For example in India the capacity of industrial in house power plants is about 12 322 MW_{el} which equals 30% of the overall electricity production [4]. Rising oil prices result in increasing electricity production costs.

The simulation results show that solar co-/polygeneration of power, heat and/or cooling can be highly profitable if the cycle design is adapted to the load profile. The main influencing factors on the technical design are the boundary conditions at the given location (i.e. climatic data, solar resource, availability of water, demand and demand profile etc), the choice of solar collector field and cost data. These parameters can be used to optimize the economic savings of a certain system. Significant savings compared to fossil fuelled solutions may be achieved by solar thermal co-/polygeneration. Higher savings were found for off-grid applications. Today's investment costs, which are more or less prototype or low quantity production costs, already allow economically feasible systems. It can be assumed that these costs will drop if it comes to series production. Today only the subsystems of a solar polygeneration system such as solar cooling, solar electricity, and solar process-heat are in use. It is necessary to set up demonstration plants in order to show the feasibility of solar polygeneration.

References

- [1] Neuhäuser, A., Sauerborn, A., Platzer, W.; „Solar Polygeneration with Concentrating Collectors“, 15th SolarPACES International Symposium, 15.-18.9.09 Berlin, Germany (2009)
- [2] Platzer, W., Final public report MEDIFRES, TIB Hannover, Freiburg (2009)
- [3] <http://solarbythewatt.com/2009/10/16/price-dollar-per-watt-large-solar-pv/> date: 16th July 2010
- [4] Price Waterhouse Coopers, Infrastructure Development Action Plan for Chhattisgarh – Final Report
- [5] M. Rommel, W. Weiss (ed.), Process Heat Collectors - State of the Art within Task 33/IV (2008)
- [6] Kaldellis J.K., Integrated electrification solution for autonomous electrical networks on the basis of RES and energy storage configurations, Energy Conversion and Management, 2008.