

Biomass Co - Generation Power Plant in Scharnhauser Park



Rafal Strzalka

Stuttgart University of Applied Sciences

Content

- Characterization of the concept for co generated heat and electricity production in HKS – Scharnhauser Park.
- Results of researches.
- Conclusion.

Biomass co generation power plant Scharnhauser Park

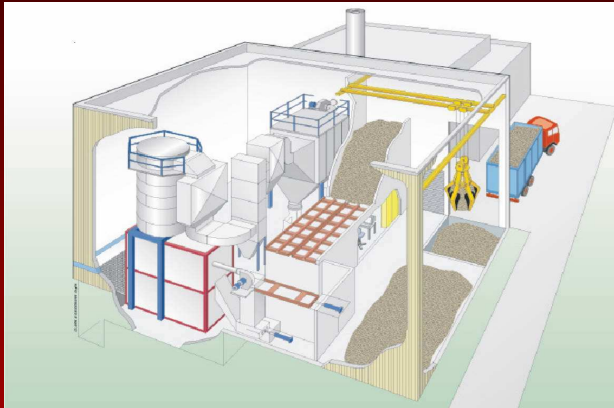

- District heating system with 80% renewable energy supply
- thermal power Biomass 6.3 MW
- Electrical power ORC-Module 1 MW
- Yearly total energy supply 31 Mio. kWh/a
- Yearly electrical energy supply ORC-Module 4,5 Mio kWh/a
- Wood Chip demand 34000 Sm³/a
- Fossil energy savings 3,5 Mio m³ Gas/a
- CO₂ Reduction 10.000 t/a



Introduction

Technology

Results

Conclusion

The wood fired power station

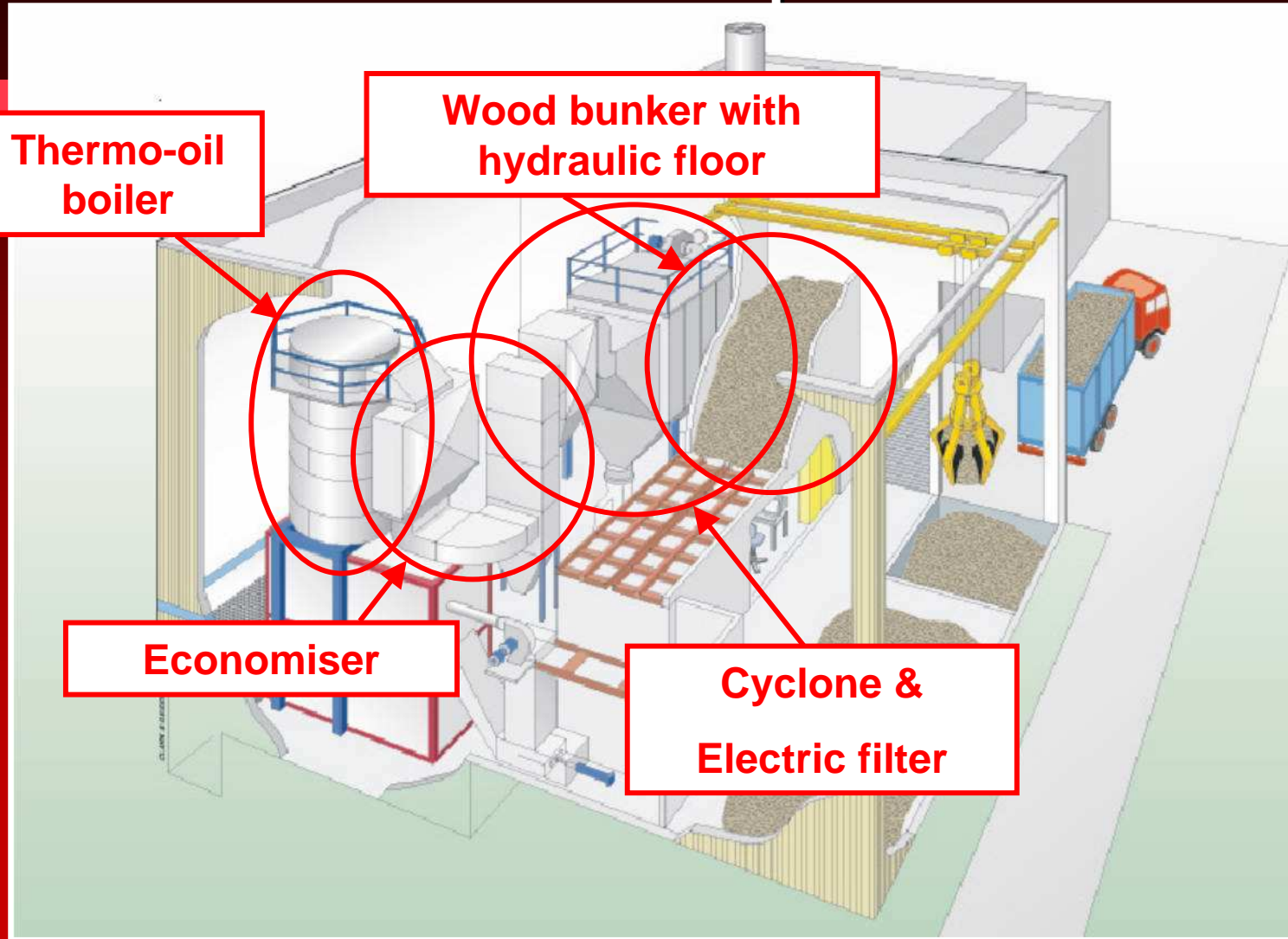

Introduction

Technology

Results

Conclusion

The ORC process

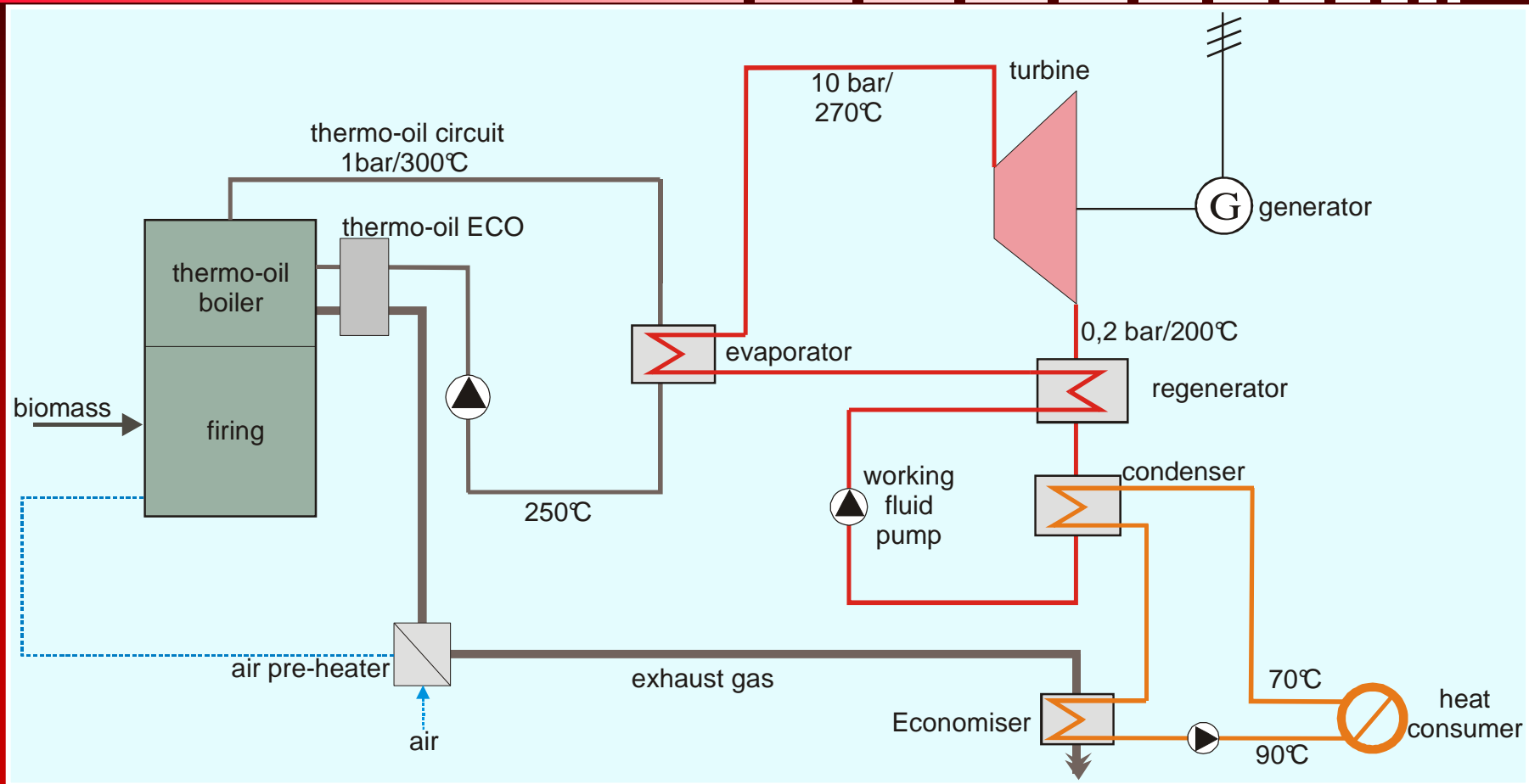

Introduction

Technology

Results

Conclusion

Energy flow and efficiency of energy generation

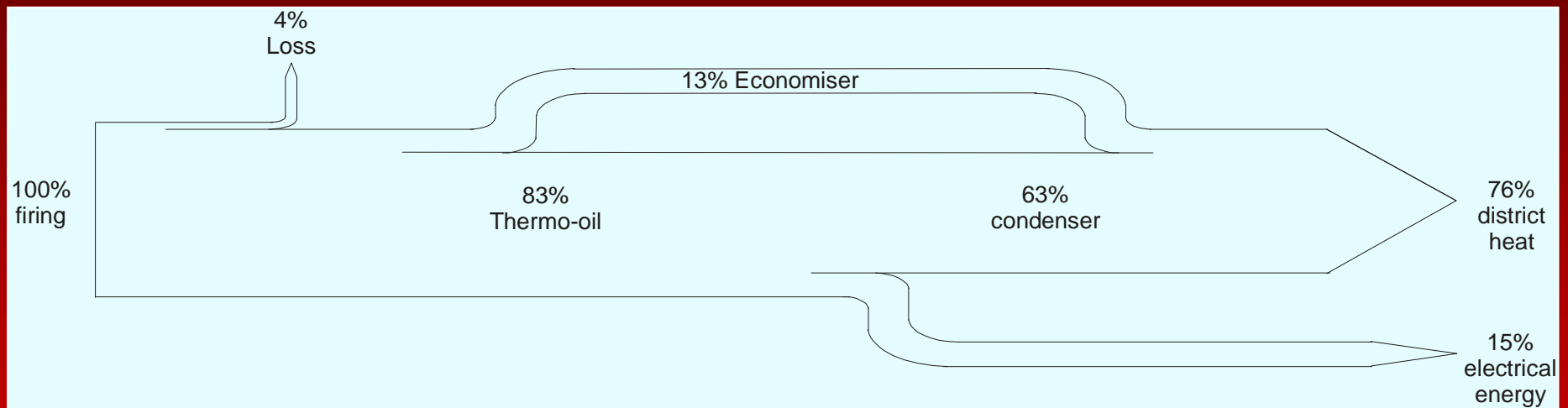

Introduction

Technology

Results

Conclusion

Raw data

- The plant operation was analyzed on the basis of energy amounts measured by energy meters.
- The raw data included also the amounts of monthly combusted wood chips.

Fuel energy value

— Generated energy — Wood supply * Asch disposal

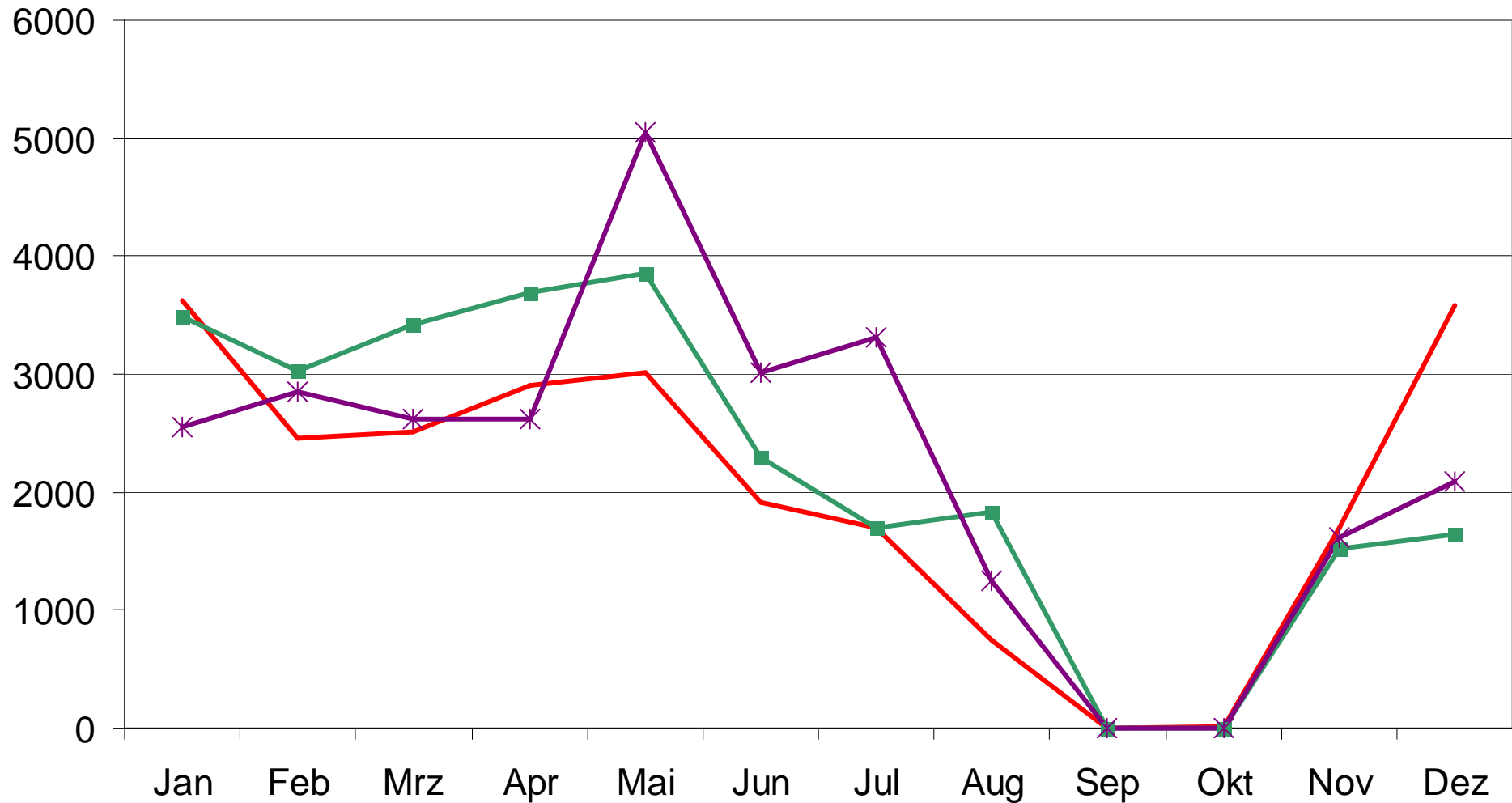

Overall efficiency

Overall efficiency

$$\eta_G = \frac{N_{el} + Q_{Heat}}{Q}$$

$$\eta_{G(Supp.)} = 79,5\%$$

$$\eta_{G(Ash)} = 92,8\%$$

Average value

$$\eta_G = \frac{\eta_{G(Supp.)} + \eta_{G(Ash)}}{2}$$

$$\eta_G = \frac{79,5 + 92,8}{2}$$

$$\eta_G = 86\%$$

Efficiency by generation of electrical power

Electrical energy efficiency

$$\eta_{el} = \frac{N_{el}}{Q}$$

$$\eta_{el(Supp)} = \frac{1349}{17421} = 7,7\%$$

$$\eta_{el(Ash)} = \frac{1349}{14727} = 9,2\%$$

Average value

$$\eta_{el} = \frac{\eta_{el(Supp)} + \eta_{el(Ash)}}{2}$$

$$\eta_{el} = \frac{7,7 + 9,2}{2}$$

$$\eta_{el} = 8,5\%$$

Discussion of the results

- The overall degree of efficiency has a normal range in respect to degrees of efficiency of modern co generation power plants.
- The electrical efficiency of the plant is relatively low.

Perspectives

The power plant is equipped with sensors for measuring of characteristically operation parameters. The evaluation of those data will allow explicit analysis of the power plant operation.

Conclusion

- Although the relatively low electrical efficiency, the ORC – technology has valuable advantages.
- As the result of the co generation power plant operation in year 2005, 17.222 MWh heat and 1212 MWh electricity were provided to the customers.